

R. KACZMAREK*[#], R. KRAWCZYK*

REQUIREMENTS RELATING TO MANUFACTURING CONSTRUCTIONS IN THE ASPECT OF CONDUCTING ULTRASONIC TESTING

WYMAGANIA ODNOŚNIE WYTWARZANIA KONSTRUKCJI W ASPEKcie PRZEPROWADZANIA BADAŃ ULTRADŹWIĘKOWYCH

Basic factors which have an influence on conducting manual ultrasonic testing of joints in the welded constructions are presented in the following article. These factors are specified on the base of the guidelines referring to conditions and methods of carrying out examinations which are currently in force in the following standards PN-EN ISO 17640 and PN-EN ISO 22825. Due to the vastness of subject of ultrasonic testing the main aim of the following article is to collect all important information which relates to design and manufacture of constructions and has a key influence on the following examinations.

Keywords: ultrasonic testing, welded joint, welded constructions, non-destructive testing of welds

W pracy zawarto analizę podstawowych czynników mających wpływ na możliwość wykonania ręcznych badań ultradźwiękowych złączy w konstrukcjach spawanych. Czynniki te oparto na wymaganiach obowiązujących norm przedmiotowych PN-EN ISO 17640 i PN-EN ISO 22825 w odniesieniu do warunków oraz sposobu przeprowadzenia badań. Celem publikacji było omówienie najistotniejszych informacji dotyczących projektowania i wykonywania złączy mających kluczowy wpływ na późniejszą kontrolę ultradźwiękową.

1. Introduction

On the stage of manufacturing of welded constructions, it is necessary to use non-destructive testing in order to control the quality of finished joints. Non-destructive examinations and a quality assurance systems according to PN-EN ISO 3834 standard are the key factors that help to manufacture and launch high quality and safe welded products into the market. Moreover, in the recent years a trend to increase requirements of welded constructions and to reduce safety factors and weight of the constructions by using high strength steel has been observed. Usage of high strength steel increases risk of welding imperfections to occur, which may lead to dangerous and expensive failures. Therefore, the requirements provided in the PN-EN 1090-2 standard recommend carrying out additional non-destructive testing, other than an obligatory visual inspection, in some cases up to 100% of welds length. For example, the EXC4 execution classes with the utilization grade $U \geq 0,5$. Thus, it is crucial to design joints and the whole construction, and it is necessary to plan the order of welding process and non-destructive inspection in advance to allow testing welded joints properly. Both the required quality level and the range of non-destructive testing should be specified in the engineering documentation of the construction. On the

other hand, the choice of methods and the selection of tested zones should be done by the 3rd level personnel according to PN-EN ISO 9712 standard, the legal provisions and the arrangements between the parties [1].

The above information, together with the order and the stage of manufacturing, on which the testing is to be performed, should be included in the technical documentation of welded construction called Welding Plan or a separately prepared Control and Testing Plan [2].

Among the methods of non-destructive testing, ultrasonic testing (UT) plays more and more significant role in the quality inspection of welded joints. It is caused by the fast development of UT equipment, which took place at the beginning of the 1990s. Mentioned development is being observed in the modern, digital ultrasonic flaw detectors with an option to record the test results, new types of ultrasonic probes (phased array probes) and using innovative ultrasonic testing techniques (Time of Flight Diffraction, UT-Phased Array etc.) An effect is a continuous development of this testing method, particularly increasing probability of detection, an improvement of evaluation accuracy and a simplification of operating. It is done thanks to simpler and more accessible visualizations and a considerable reduction of time necessary to conduct a test. Reduction of an equipment prices has a great influence on

* CZESTOCHOWA UNIVERSITY OF TECHNOLOGY, 69 J.H. DĄBROWSKIEGO STR., 42-201 CZĘSTOCHOWA, POLAND

[#] Corresponding author: rafal.kaczmarek133@gmail.com

an increasing share of ultrasonic method on the field of non-destructive testing. Moreover, the cost of conducting UT is lower in comparison to the alternative radiographic testing (RT). What is more, an increase of ultrasonic testing popularity is observed in a growing interest in trainings organized by e.g. Welding Institute in Gliwice. The number of personnel trained in ultrasonic testing method is constantly raising.

2. The factors affecting the choice of ultrasonic testing method

Most standards and item regulations for a specific product recommend to conduct the required range of non-destructive tests without indication of specific testing method. In the case of detection of internal discontinuities, the testing range is given in the percentages for the RT or UT method. The choice between the methods is made on the base of recommendations of PN-EN ISO 17635 standard and other factors described in the further part of the article. In the table 3 of the standard, choosing criteria, depending on the kind of the parent material, type of a joint and its thickness, are specified. In the case of ferrite steel joints, ultrasonic testing is recommended for the high and medium thickness ($t \geq 8\text{mm}$), for both the butt joints and T-joints. In the case of the T-joints, UT is usually chosen due to difficulties of RT, which are caused by the geometry of a joint. A similar situation takes place in the case of butt joints, when there is an access just from one side (a face or a root side), as the RT method always requires an access from both sides of a joint. For the small thickness ($t < 8\text{ mm}$) and for the austenitic steel PN-EN ISO 17635 standard recommends mostly RT, and UT only in the limited range. However, it is possible to conduct the test with certain limitations [3]. Except of PN-EN ISO 17635 requirements, there are numerous factors which have an influence on a choice of testing method. They are as follows: detection discontinuities which is characteristic for this method of testing, costs of testing and other inconveniences which are necessary to guarantee fulfilment of relevant industrial safety regulations in the area of testing.

While choosing a method of internal discontinuities detection for a specific case an ability to detect a type of discontinuities that is expected to dominate or determine a static and dynamic strength of a joint should be considered. In most constructions, especially those the most responsible, which operate in variable and dynamic stresses, the key issue for the safety operation is to detect flat discontinuities. They create sharp geometrical notch which accumulates stresses and initiates the formation of fragile cracks, which in turn leads to a sudden, dangerous breakdowns. In the welded constructions, susceptible to these kind of damages caused by the presence of discontinuities such as: cracks, incomplete fusion, lacks of weld penetration, it is worth using ultrasonic testing, which is known to detect the discontinuities in a very effective way. Alternative X-ray testing shows a limited ability to detect cracks and incomplete fusion as well as to determine location of the nonconformities [4]. Additional reason for choosing ultrasonic testing is the fact that it is a cheaper method to implement. Additionally, it does not require to evacuate personnel while testing, as it is in the case of majority radiographic techniques. It allows to reduce

the costs of inspection and avoid to disturb the work of the personnel around the testing area.

Nowadays the UT is a key non-destructive testing method on a field of welded joints examination. In comparison to RT, it allows to conduct a relatively cheap and fast inspection of welded joints, without disturbing a production process. Moreover, the UT method is also more effective in detecting the most dangerous, flat welding imperfections. However, it is essential, since a beginning of a project, to design joints and an entire construction as well as plan the manufacturing and quality inspection in advance in this way, that it would be possible to conduct the UT of the selected joints.

3. Technological factors which determine the ability to conduct the ultrasonic testing

Not in all cases ultrasonic testing can be conducted. There are numerous technological factors in the production process, which limits the use of the method. An influence of the above factors depends on a characteristics of the UT method or is determined by a standard which specifies, whether the ultrasonic method can or cannot be used. For example, test conducted by the specific probe with a specified angle of refraction in a determined level of testing can be impossible due to the lack of useful scanning surfaces.

The basic technological factors, which have an influence on carrying out ultrasonic inspection, are:

- type of a welded joint and a weld,
- thickness of a joint,
- type of parent metal of a joint,
- an access to the tested areas,
- obstacles on the way of the ultrasonic wave beam,
- grinding off an excess metal on the face and/or root of the butt weld,
- usage of a steel backing,
- type and an angle of bevelling.

4. A type of welded joint and a weld

The UT method is the most widely used in the case of butt joints of metal plates and pipes of $t \geq 8\text{ mm}$. The above testing is conducted according to the requirements of PN-EN ISO 17640 standard and they are relatively easy to be performed. PN-EN ISO 17640 standard provides also recommendations how to test:

- the T-joints,
- set-through nozzle joints,
- set-on nozzle joints,
- node joints of tubular structures,
- structural L-joints,
- cruciform joints.

Testing is carried out by using angle and straight beam probes, depending on the type of a joint, taking into account the requirements included in attachment A of PN-EN ISO 17640 standard. The requirements refer to the location of a probe, a number of scans, different angles of initiating beams etc. The requirements depend on an established level of testing and an agreement between the parties. The probability of detecting

imperfections increases with changing the level from A to C. The standard [5] requires to conduct the scanning for lateral indications only on level C. However, the need to search for them may be imposed also on level A and B on a base of an agreement.

PN-EN ISO 17640 standard does not assume to test the joints with fillet welds. For this reason, if detection of internal discontinuities of the joints in a designed construction is to be conducted, fillet welds should be replaced by butt welds to enable conducting inspection based on the requirements of the standard specifications. This solution causes a grow of costs of manufactured construction. In the other hand, the strength of joints increases as well, especially the variable and dynamic strength, which is a key factor in the case of responsible constructions.

Fillet welds testing is difficult and inaccurate due to the problem of the precise description of the fusion line. If the fillet welds has been used in a construction that is to be inspected, the inspection should be conducted by the operators with a great experience in the ultrasonic testing. The reason is, that there often appear very similar oscillographic pictures for the fillet welds in the case of occurrence or lack of welding imperfections. It makes the detection of flat welding discontinuities such as: lack of weld penetration or incomplete fusion difficult. Implementation of the method requires to prepare reference block with fillet welds with artificial welding imperfections of mentioned types in order to help to interpret the oscillographic pictures of imperfections of an actual construction [6]. It is worth mentioning that there are no standards which describe ultrasonic testing of joints with fillet welds. Therefore, there is lack of any regulations, which could serve for the parties of a contract as a base to specify the technical details of an inspection and define the acceptance criteria.

5. A joint thickness

For the joints of 8 mm or thicker plates the manual ultrasonic testing is carried out on the base of PN-EN ISO 17640 standard, and the level of acceptance is taken according to PN-EN ISO 11666 standard. It is worth mentioning that the model of discontinuity assessment accepted in PN-EN ISO 11666 standard, with a stepped change of the testing sensitivity, may lead to different test results for some particular joint thickness. They can be caused by tiny measuring errors of the thickness of welded plates. In the range of 14,9 to 15 mm there are both a stepped change of a diameter of a projector reference (for the technique 2 adjusting the level of reference DGS), and a stepped change of the levels of acceptance for the readings of the length shorter than the thickness of the material ($l \leq t$) in the above range [7].

If a joint that is thinner than 8 mm cannot be tested by the radiographic method due to the lack of an access from one side, and regulations require to inspect it for the internal discontinuities, the UT method can be implemented with some limitations. The limitations result from the fact, that while testing by the angle probe, an ultrasonic beam quickly reaches the width equal to the thickness of the tested element. Moreover, a ultrasonic wave transformation occurs (the

transverse into longitudinal wave and the longitudinal into transverse one) as well as the surface and the Lamb's waves appear [8]. It causes great difficulties to estimate the depth of deposition. The size of discontinuities and an accuracy of the estimation is low. An additional difficulty is a lack of current standards for testing these kind of elements, giving the levels of acceptance necessary to evaluate joints. There is a local standard PN-90/M-70055/03 to test 3 to 8 mm joints, however, it is outdated. There is a helpful article [8], where a way of testing, according to ISO 17640, is suggested. The article refers to ultrasonic testing of thin-walled welded joints 3 to 7 mm thick by using singular angle probe. It suggests using two levels of acceptance 1 and 2 for the B level of the joint quality.

6. A material of a joint

A key influence in the ultrasonic testing is a type and a microstructure of the material of a joint. It relates to both the parent material and the filler material. The inspection of the joints with a ferritic microstructure, in which case suppression of ultrasonic waves is low, is relatively easy to be conducted. In that cases standards PN-EN ISO 11666 and PN-EN ISO 17640 are used. In the case of austenitic high-alloyed steel, ferrite-austenitic (duplex steel) or nickel based alloys the ultrasonic testing is difficult to conduct and it is a great challenge for the testing personnel. Mentioned difficulties are caused by unfavourable microstructure, a large grain size as well as a huge diversity of acoustic properties of the joints. It results in high suppression of ultrasonic waves on a coarse-grained microstructure of the parent metal with a dendritic microstructure of a weld. The bigger the grains are, the more difficult the execution of ultrasonic testing is. Therefore, the joints of small thickness welded with low linear energy, which means that heat was quickly led off a joint and did not cause the grain growth, do not cause much problems while tested. In the austenitic welds of thick plates, the lack of phase transitions causes the formation of coarse-grained microstructure in the heat affected zone as well as the characteristic transcrystalline dendritic structure of a weld. The grain size is the greater, the more heat is introduced to the weld during the welding process. Such joints cause great difficulties when ultrasonic tested [12, 13].

The key factors, which affect the suppression level in the welded joints of austenitic steel are: suppression within the grain borders, transformation of one type of waves into the another and a deflection of a direction of ultrasonic wave beam. Unfavourable structure of a weld is also the reason of a frequent occurrence of apparent indications.

PN-EN ISO 17640 standard, which is dedicated mainly for ferrite steel testing, includes however testing level D devoted to a special use inter alia for the materials other than non-ferritic materials. In the industry experience the most frequent use refers to testing austenite steel joints. In this case it is required to take all the actions described in PN-EN ISO 22825 standard titled 'Non-destructive testing of welds – ultrasonic testing – testing of welds in austenite steels and nickel-based alloys'. The above procedures require to prepare reference test pieces in order to specify an initial testing procedure, set up a sensitivity level, and then in case of a positive evaluation,

prepare a final procedure of ultrasonic testing [9]. A material, a preparation and a procedure of welding as well as a surface condition of a reference test pieces and their geometry should be similar to an actual tested element. Testing of the actual welds should be done in accordance to the prepared procedure, based on the results of the proper number of sample pieces, with genuine or artificial discontinuities. Conventional transverse waves angle probe are used to test thinner plates (up to 15 (25) mm). But in the case of plates thicker than 25 mm, it is necessary to use longitudinal waves probe to test a joint. It is also recommended to grind off an excess of metal and to ensure an access from both sides of the weld. Additionally, it is important for testing personnel to be familiar with grain orientation in a tested weld [6, 9]

7. An access to a scanning surface

Another factor which influences an ability to implement the ultrasonic testing method is an access to the area where the scanning is to be carried out. A size of a required area depends on a type of a probe, an angle of probe (in case of angle probes) and also a thickness and a shape of a tested element. According to PN-EN ISO 17640 standard, inspection of the butt joints with an angle probe requires the width of a scanning zone equal at least $1,25 \cdot p$ (where: p is a skip distance).

The Table 1 shows a required width b depending on the angle of a probe for the most frequent thicknesses of joints in the range between 8 to 34 mm. It is crucial for inspection to be conducted correctly, according to the standards, to provide an access on a required width b from both sides of a joint, which means from the both sides of the face or from both sides of the root (Fig. 1). Moreover, it is necessary to add to the value b shown in the Table 1 at least a half of the length of a probe, as they do not include the size of a probe but only the skip distance.

While testing sample joints in the process of implementing a new welding technology, not always a sufficient width of plates to conduct the UT is provided. As the analysis presented in the article [10] shows, a required by PN-EN ISO 15614 standard size of sample joints guarantees a necessary scanning

zone width on the whole range of thickness only in case of the angle of beam induction $\alpha=45^\circ$. For the greater angles and thicker materials (that is $\alpha=60^\circ$ and thickness more than 34 mm and $\alpha=70^\circ$ and thickness more than 20 mm) the width of sample plates is insufficient to fulfil the requirements of a minimum width of scanning zone, which equals $b=1,25 \cdot p$.

The ultrasonic testing may be difficult or impossible to conduct because of an insufficient width of an available scanning zone due to the small distance between particular elements of the construction. Additionally, a location of a weld in a complex construction may cause difficulties in reaching the area of the weld by operator's hand with an ultrasonic probe. In the case of box elements, some of the most favourable scanning surfaces may be enclosed inside, making an inspection difficult or impossible. Due to the above reasons, in the case of complex constructions the UT inspection should be conducted during the process of manufacturing, before successive elements cause difficulties with conducting of the test (e.g. before welding the ribs).

The testing should be conducted according to the 'Control and Testing Plan' prepared on the base of a project before the manufacturing begins. It is also vital to take into account on the early stage of designing not only the need to access the particular elements of the construction in order to make joints, but also to test them. It requires agreements between a design engineer, a manufacturer and a inspecting institution in some cases.

Figure 1 and 2 show a testing surface including width of the scanning zone according to PN-EN ISO 17640 for: butt and T-joint. The positions of the probe is marked with capital letters, and the width of the scanning zone with small letters. A scanning surface is chosen on the base of the standard recommendations depending on the level of testing and the thickness of the tested element ([5], table A.1 to A.7). Above recommendations refer to the location of the probe while scanning by the angle and straight beam probe on the longitudinal indications, and by the angle probe on the transverse indications. The required width of the scanning zone is also given, which in case of butt joints is $b=1,25 \cdot p$, and in the other cases is $1,25 \cdot p$, $0,75 \cdot p$ or $0,5 \cdot p$ depending on the type of joint and the positions of a probe.

TABLE 1

Required width of a scanning zone b , when examine butt welded joints of plates and tubes

Thickness of the joint t , mm	Required width of a scanning zone b , mm (for different angles of initiating ultrasonic wave α)			Thickness of the joint t , mm	Required width of a scanning zone b , mm (for different angles of initiating ultrasonic wave α)
	$\alpha=45^\circ$	$\alpha=60^\circ$	$\alpha=70^\circ$		$\alpha=45^\circ$
8	20,0	34,6	55,0	22	55,0
10	25,0	43,3	68,8	24	60,0
12	30,0	51,9	82,5	26	65,0
14	35,0	60,6	96,3	28	70,0
16	40,0	69,2	110,0	30	75,0
18	45,0	77,9	123,8	32	80,0
20	50,0	86,5	137,5	34	85,0

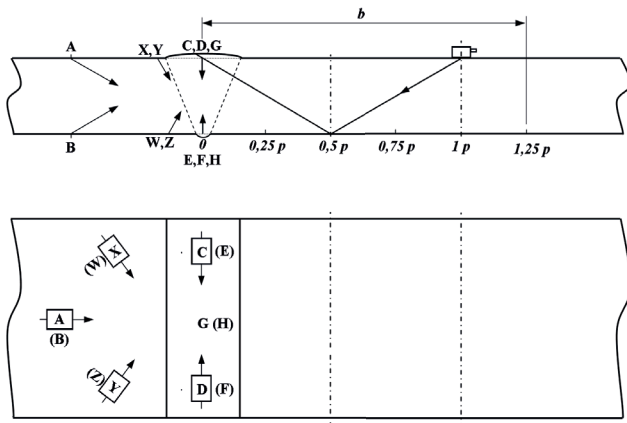

Fig. 1. Scanning zone during an examination of butt welded joints of plates and pipes

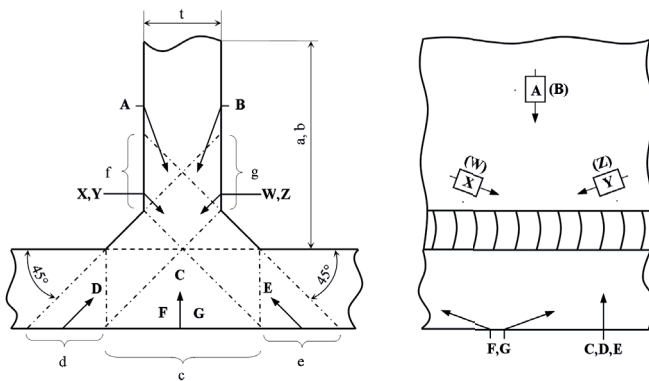

Fig. 2. Scanning zone during an examination of T-joints

8. A technological elements and other obstacles on the way of an ultrasonic beam

There are often difficulties to implement UT method caused by presence of obstacles on the way of an ultrasonic beam. These obstacles may be the drilled holes in the basic material, reflection off an ultrasonic beam, welded ribs, welded stud or protective coats. They cause difficulties in transfer of the ultrasonic beam from the probe to inspected material. If the test is to be conducted on the stage of manufacturing, the examination should be undergone before drilling the holes, welding the ribs and painting. If the test is conducted during exploitation, it is required to remove carefully protective coats and rust from the scanning surface beforehand.

9. Grinding the face or/and the root of the butt weld

If grinding of the face or/and the root of a butt weld is provided according to the project of the construction, then it gives additional opportunity to examine butt welded joints by:

- using a straight beam probe – to examine the thickness of the joint,
- using a angle probe – to examine alongside the weld axis for the transverse indications.

A removal of an excess metal also eliminates a danger

of occurring apparent indications, caused by the shape of the face or the root of a weld, that very often leads to an incorrect evaluation. Such situation may lead to both rejection or unnecessary repair of the joint in an area where an examination suggested an apparent indication as well as to the more dangerous reverse situation, that the indication is named as apparent while in fact it is a real discontinuity. Therefore, it is vital to avoid the factors, which cause an excess penetration bead in a root (a considerable distance between the edges of welded elements, too high electric current intensity or making root run with the spray arc) or an improper shape of an excess weld metal (improper parameters of welding, inadequate skills of a welder) [11].

Machining the face and the root in the butt weld joints also helps to increase the fatigue strength of the joint by removing geometrical notches. Grinding is required to conduct UT on the examination level C. It is used in the responsible constructions, due to the requirement to test the whole length of the weld using the straight beam probe and the angle probe. The requirement is valid for the whole range of thickness of plates. Machining of the weld is also recommended in the examinations of the austenitic steel due to the need of removing apparent indications.

10. A usage of a technological steel backing

A technological steel backing, which remains as a part of a joint after a welding process, very often causes inexperienced UT operators a lot of difficulties. It leads to disturbances when scanning is conducted by the angle probe perpendicularly to the axis of the weld. When the beam reaches the root, there is no reflection like in the typical butt joint, but ultrasonic waves penetrate into the technological steel backing, and then it reflects back from its surface. It leads to the occurrence of a high amplitude peak for a way of slightly exceeded half of the skip distance. For an established thickness of the joint, an echo witch not include a technological steel backing, is calculated by the ultrasonic flaw detector and interpreted as an indication on the depth lower than the thickness of the material. It results in the common problems with an interpretation of the described type of indications.

11. A type and an angle of bevelling

One of the requirements of the PN-EN ISO 17640 standard is to use such an angle of introducing that it provides the beam as perpendicular as possible to the bevelled edge of welded elements. It is done in order to increase possibility of detection of a lack of side fusion, which are oriented to the beam in the same way as a bevelled edge. If in the echo method the above assumption is not fulfilled, then the beam may hit the large lack of fusion and to be reflected in an direction, that it never come back to the transducer. As a result no impulse from this discontinuity appears on the ultrasonic flow detector screen. The result of the above mismatch can lead to the lack of detection of the numerous systematically occurred lack of fusions, because all of them are oriented in the same direction. Therefore, it is vital to fulfil the mentioned assumption of the standard. Moreover, the

inspecting personnel must know the type and angle of bevelling of an element to match the angle of the probe. Unfortunately, there is a huge inconvenience due to the small selection of the conventional angles of probes used in UT method.

Among the five types of probes with angle equal 35°, 45°, 60°, 70° and 80° accessible on the market, the most frequently used are 70°, 60°, 45°. They fulfil the requirements of the standard only in the case of the bevelling angles equals to 20°, 30° and 45°, that is, groove angles are 40°, 60° and 90° (taking into account V or Y bevelling). The probe of 45° angle does not fulfil the requirements for any of the bevelling angles commonly used in welding technology. The best is the probe of 60° angle, with a 30° bevelling angle, with is often used in MMA and MAGS (MIG/MAG) methods of welding. The probe of 70° angle is the good one to use in case of a submerge arc welded elements with a 20° bevelling angle [11]. In the last example, the thickness of examined elements may cause problems, as it is often quite high. It often causes problems during tests with the probe of 70° angle due to the vast area of the scanning zone and long way of the ultrasonic beam. On the other hand, the probe of 45° angle does not fulfil the requirements of the above standard entirely.

As we can see, the choice of the probe used in ultrasonic testing requires a compromise between the detection of potential discontinuities and a comfort and a speed of undergoing examinations. These problems are partially eliminated by using the phased array probes in UT-PA technique, operating in a large range of angles giving a possibility of a free adjustment of the beam angle.

12. Summary

An ultrasonic method of detecting inner discontinuities in the welded joints shows many important advantages, compared to the other NDT methods. Some of them are as follows: great detection of flat discontinuities, a possibility to measure the depth of deposition or the lower cost of examination in comparison to the alternative RT method. The above advantages can be utilized to inspect a manufactured construction by conducting the UT. But it is vital both on the stage of designing and manufacturing the construction to take into account the factors described in the article, which determine the possibility to undergo UT examinations. It often requires a cooperation between particular specialists who are involved in the process of manufacturing the construction such as: designing engineers, welders and the NDT personnel in particular. If the agreements are made on the stage of designing or on the early stage of the manufacturing of a construction, then the ultrasonic testing can be done without unnecessary difficulties. Moreover, a required quality may be confirmed and finally an acceptance may be provided. It is even more important in some constructions, when the possibility to examine joints before welding next elements is the only way to do so. Later, these elements may be entirely inaccessible. Therefore, the key issue while preparing 'Welding Plans' or 'Control and Examination Plans' is an individual approach to each, especially a complex construction. It requires an accurate analysis how particular operations are

being conducted, especially these witch serves for merging and welding elements. This analysis should take into account all the factors described in the article such as: type of a joint and a weld, a thickness of examined elements, an access to the examined areas, grinding off an excess metal of a face or a root of a weld, usage of a technological steel backing, etc. [14]. In this way, the inspection may be planned to be executed on an optimal stage of manufacturing, when a inspection of a joint is relatively easy. A result of these actions is expected to be high quality constructions, that the quality is indisputable confirmed by ultrasonic examinations.

REFERENCES

- [1] PN-EN 1090-2:2008, Wykonanie konstrukcji stalowych i aluminiowych - Część 2: Wymagania techniczne dotyczące konstrukcji stalowych.
- [2] J. Słania, Plany spawania. Teoria i praktyka, Agencja wydawnicza SIMP, Redakcja Przeglądu Spawalnictwa, Warszawa (2013).
- [3] PN-EN ISO 17635:2010, Badania nieniszczące spoin – Zasady ogólne dotyczące metali.
- [4] J. Czuchryj, M. Stachurski, Badania nieniszczące w spawalnictwie, Wydawnictwo Instytutu Spawalnictwa, Gliwice (2005).
- [5] PN-EN ISO 17640:2011, Badania nieniszczące spoin – Badania ultradźwiękowe złączy spawanych.
- [6] A. Szymański, Kontrola i zapewnienie jakości w spawalnictwie. Tom 2, Wydawnictwo Politechniki Śląskiej, Gliwice, (1998).
- [7] R. Krawczyk, M. Luto, P. Wojtas, Analiza dokładności oceny niezgodności spawalniczych wykrywanych w badaniach ultradźwiękowych, Biuletyn Instytutu Spawalnictwa w Gliwicach **3**, 40-44, (2010).
- [8] M. Stachurski, Badania ultradźwiękowe połączeń cienkościennych (o grubości 3-7mm), Biuletyn Instytutu Spawalnictwa w Gliwicach **2**, 57-61 (2005).
- [9] PN-EN ISO 22825:2006, Badanie nieniszczące spoin – Badanie ultradźwiękowe – Badanie spoin w stalach austenitycznych i stopach na bazie niklu.
- [10] R. Kaczmarek, Badania ultradźwiękowe złączy spawanych. Praca magisterska. Wydział Inżynierii Mechanicznej i Informatyki Politechniki Częstochowskiej, Częstochowa, (2013).
- [11] Praca zbiorowa, Poradnik inżyniera. Spawalnictwo. Tom 2, Wydawnictwa Naukowo Techniczne, Warszawa (2005).
- [12] J. Słania, Influence of phase transformations in the temperature ranges of 1250-1000°C and 650-350°C on the ferrite content in austenitic welds made with T 23 12 LRM3 tubular electrode. Archives of Metallurgy and Materials **3**, 757-767 (2005).
- [13] G. Golański, P. Gawień, J. Słania, Examination of coil pipe butt joint made of 7CrMoVTiB10 – 10(T24) steel after service. Archives of Metallurgy and Materials **2**, 553-557, (2012).
- [14] R. Kaczmarek, R. Krawczyk, Analiza wymiarów złączy próbnych w procesie kwalifikowania technologii spawania wg PN-EN ISO 15614-1 w aspekcie badań ultradźwiękowych wg PN-EN ISO 17640, Biuletyn Instytutu Spawalnictwa **4**, 52-56 (2014).