

P. TRACZ², K. WACŁAWIAK^{1*}, J. CHRAPÓŃSKI¹, R. POPIEL²

STATISTICAL ANALYSIS OF PROPERTIES OF TECHNOLOGICAL CHARGE AND MANUFACTURING TOLERANCE OF THIN-WALLED SECTIONS IN PROCESS OF MULTI-WORKSTATIONS ROLLER BENDING

The studied collecting electrodes for electrostatic precipitators are cold-rolled formed. Here Sigma 750 open section was manufactured of DC01 steel grade. Length of the electrodes ranged from 8 to 13 meters, all were thin-walled of 1.5 mm. Tolerance of their manufacture is strictly set. A database of material properties, chemical composition, and a set of final tolerance of manufactured profiles has been collected. At first basic statistics for the data has been done. Finally statistical relation between the material composition and profile geometrical tolerance has been studied, next between the material mechanical properties and profile geometrical tolerance has been examined.

Keywords: technological charge; cold-rolled forming; statistics; manufacture tolerance

1. Introduction

Originality of this research arises from the following: large database of material properties and post-manufacture shape parameters has been collected. A thin-walled, cold-rolled profile of a collecting electrode for electrostatic precipitators has been studied. Material properties like chemical composition, strength parameters, sheet thickness for 12 specimens were stored and statistically aggregated. Geometrical parameters of the profile section were evaluated alike. Publications often present single numbers of material properties like Young's modulus or carbon content, without their natural variation stemming from apparatus accuracy or natural distribution. Based on this set of data authors carry out numerical modelling of profiling processes. Actually a producer buys rolls of sheet from different heats. Although the stock meets standard requirements for the chosen material grade, one observes chemical composition, yield and tensile strength, elongation, or hardness range significantly. Even rolls from a single heat also differ. A sheet producers often keep material parameters close to limits, for instance the sheet thickness is close to its minimum because of its cost. Apart from material properties cold-rolling itself leads to a variation of final shape parameters and dimensions. End products must fulfil project tolerance. Obviously the tolerance is influenced by above-mentioned material properties and also production line conditions. In scientific

publications papers on production of collecting electrodes are rare. Firstly their section is complex, though open. Secondly producers design and set up production lines on the basis of their experience and trial-and-error method. Thirdly simulations of roll-forming processes using Finite Elements Method (FEM) are new and have just begun helping manufacturers. Majority of papers describes measurements at test, several roll facilities, or multi-roll production lines, then FEM software of general use like Abaqus or specialised like Copra are utilised in order to predict or repeat the measured parameters.

Bowing and twisting of roll formed a C profile were analysed in a publication from 2013 [1]. Both experimental and numerical analyses were done. A high strength and mild steel grades were compared. The C profile had different flange heights and was bent via three passes. A detailed analysis of wrinkling during a innovative flexible roll forming was presented in a paper from 2015 [2]. Again experimental and numerical, by Abaqus code, approach was used. Next publication from 2015 [3] examined cold roll forming of a channel section. By experiments and numerical simulations authors tried to find relation between process input parameters like bending angle increment, strip thickness, flange and web width of the section, speed and distance between the rolls, or friction coefficient, and final stress-strain fields resulting in shape defects like bowing. A sort of statistical input for finite element method simulation was described in a paper

¹ SILESIAAN UNIVERSITY OF TECHNOLOGY, DEPARTMENT OF MATERIALS TECHNOLOGIES, 8. KRASIŃSKIEGO STR., 40-019 KATOWICE, POLAND

² PST CONSULTING RAFAŁ POPIEL, POLAND

* Corresponding author: krzysztof.waclawiak@polsl.pl



from 2016 [4]. Authors used Copra software to predict U-shape profile with 6 stations of rolls. Three parameters each with three values: width, thickness, and radius of bending were used in simulations, which made 27 possible combinations. Al-Mg steel grade was analysed. Then experiments at a 4-stage forming machine were carried out to verify the simulation results. Authors conducted the unvaried sensitivity study in order to verify how these three parameters influence the shape defect like spring back angle. They found that the thickness is the most influential parameters among the studied, while sheet width the smallest. A recent paper [5] described profiling of trapezoidal aluminium alloy sheet was simulated in Abaqus software. Influence of the following parameters was studied: the number of ribbing, the coefficient of friction, the distance between profiling stations, bending angles in individual stations, the thickness of sheet on the transverse bend of the profile. Based on the numerical results a linear regression model describing influence of these parameters on the studied quantity of transversal bending was estimated. In a newest paper [6] results of numerical simulation of the beam profiling process as car components were presented. The profile project was developed with the COPRA RF software, whereas profiling with Abaqus. The influence of 3 parameters was studied: belt thickness, height of the profiled section and profiling speed on the straightness of the edges of the ready profile. Based on the obtained results, it was found that each of the parameters significantly affects the tested parameter (Edge Wave Defect) with particular indication of the thickness of the steel strip.

1.1. Description of the production line

Collecting electrodes are steel thin-walled profiles with open cross-section. Technological process of manufacturing collecting plates consists of multi-stage roll bending of a cold-rolled strip. Usually thickness of a technological stock ranges from 1.2 to 1.5 mm. Analysed electrodes were designed with a constant bending radius. Profiling is realized by using progressive method of calibration. In the analysed process, bending of a steel strip was carried out from the central part of profile to the outside. For production of collecting plates like C-750 profile, 18 profiling workstations are sufficient along with three straightening ones. The distance between each workstations was 500 mm and was constant, impossible to have modified during production. The straightening workstations placed at the end of a machine table had a vertical adjustment and an operator could correct width of central plane of collecting electrodes. They were not driven. A bend zone of a steel strip during manufacturing through all bending rolls was controlled at all surfaces.

In this case technological stock was a cold-rolled steel strip grade DC01 according to Polish and European standards [7,8], 1.5 mm thick and 958 mm wide. The internal bending radius was 6.5 mm. Cutting process of end products was made by using a punch tool, implemented to a hydraulic press, set behind the profiling machine. Apart from cutting on fixed length, also

assembly holes in profiles were punched with this tool. Length of collecting electrodes was adjusted by a bumper located in the roll table, linked with the hydraulic press. In Fig. 1 all, but buckling, geometric features under study were presented, namely bend at both sides Ac and Bc, distance C1, C2 and E1, E2, twist H, camber K.

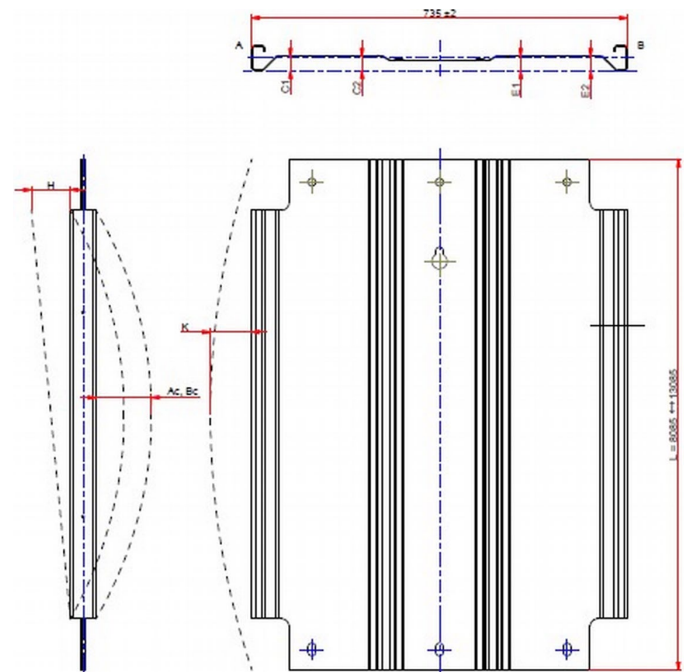

Fig. 1. A detailed drawing of the studied Sigma C750 profile

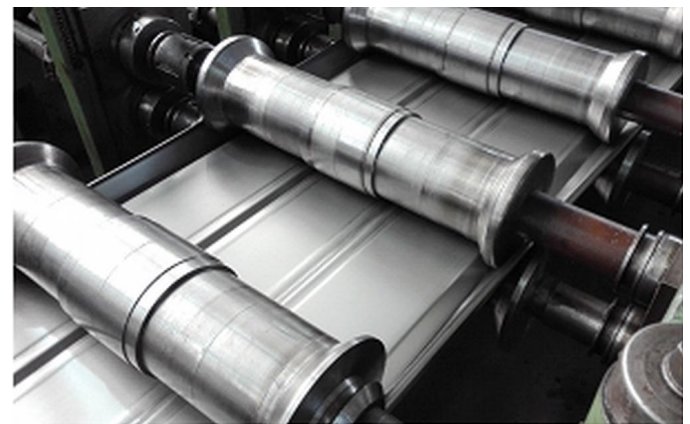

Fig. 2. A group of profiling rolls (top), purchased rolls, and cut-out sections for analyses (bottom)

2. Experimental

In this chapter study into how chemical composition and material properties differ for each heat, and how the differences affect the feedstock, has been presented. In order to accomplish this task a set of data was collected. It originates from one large production order – 816 collecting electrodes of 5 lengths. Weight of the delivered material was around 93 tons, and came from 7 heats. It was supplied by 1 wholesale company and delivered in 12 rolls.

2.1. Materials properties

Material properties and its chemical composition were measured by testing specimens and are presented in TABLE 1. Number of specimens totalled 12, 1 specimen was cut out from each roll. Rolls were marked as r1 to r12. Below a detailed statistics analysis is presented. In TABLE 2 statistical parameters of each roll are presented. The following analytical statistical parameters are used (from basic to more sophisticated): mean, sample standard deviation, median, minimum, maximum, skewness, kurtosis, quartile 1 and 3, percentage ratio of sample stand-

ard deviation to mean value (coefficient of variation), percentage ratio based on quartiles and median value calculated for a set of the properties. These are as follows: chemical composition regarding content of carbon, manganese, phosphorus, sulphur, strength properties like yield and tensile strength, elongation, and hardness.

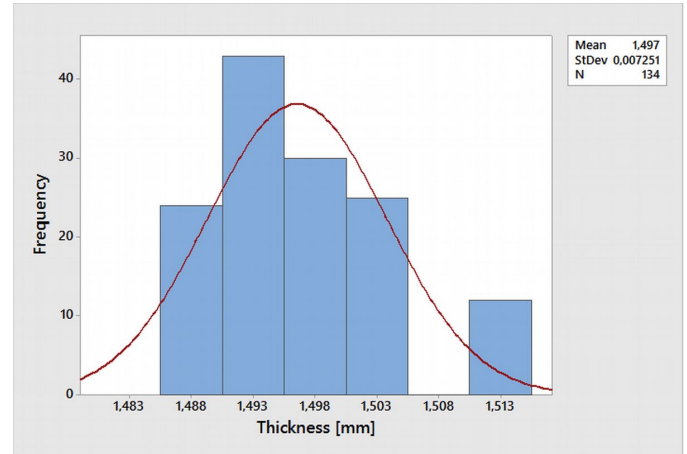

Fig. 3. Frequency and number of specimens for thickness analysis of the charge sheet

TABLE 1

Measured material properties for each roll

Rolls	g [mm]	C [%]	Mn [%]	P [%]	S [%]	R _{p0.2} [MPa]	R _m [MPa]	A ₈₀ [%]	HV10
r1	1.513	0.051	0.20	0.009	0.007	250	357	36.5	115
r2	1.501	0.049	0.21	0.013	0.008	223	348	35.2	117
r3	1.487	0.050	0.20	0.013	0.009	222	346	35.5	121
r4	1.499	0.050	0.20	0.008	0.006	228	348	38.0	114
r5	1.495	0.041	0.23	0.009	0.007	227	342	35.5	114
r6	1.498	0.040	0.23	0.009	0.007	254	353	36.9	116
r7	1.487	0.042	0.18	0.008	0.005	212	338	36.2	114
r8	1.492	0.042	0.18	0.008	0.005	213	338	36.5	114
r9	1.491	0.043	0.18	0.008	0.005	227	338	36.5	114
r10	1.500	0.058	0.19	0.008	0.006	242	354	35.9	117
r11	1.493	0.042	0.20	0.005	0.006	220	338	37.5	110
r12	1.502	0.042	0.20	0.005	0.006	233	340	38.1	112

TABLE 2

Statistical analysis of properties of material from all heats (12 rolls)

Statistical measures	Chemical composition [weight%]				R _{p0.2} [MPa]	R _m [MPa]	A ₈₀ [%]	HV10*	g [mm]*
	C	Mn	P	S					
Mean x	0.046	0.2	0.009	0.006	229.2	344.9	36.52	114.9	1.497
Sample standard deviation s	0.005	0.016	0.002	0.001	12.48	6.63	0.942	2.72	0.007
Median M	0.043	0.2	0.008	0.006	227	344	36.5	114	1.496
Minimum	0.04	0.18	0.005	0.005	212	338	3.2	100	1.487
Maximum	0.058	0.23	0.013	0.009	254	357	38.1	121	1.513
Skewness	0.802	0.566	0.456	0.611	0.665	0.47	0.369	0.623	0.656
Kurtosis	-0.34	-0.392	-0.285	-0.471	-0.488	-1.16	-1.0	0.559	0.103
Quartile q1	0.042	0.19	0.008	0.006	222	338	35.5	114	1.491
Quartile q3	0.05	0.2	0.009	0.007	233	348	37.35	116.75	1.501
s/x, %	11.24	8.02	29.41	19.02	5.45	1.92	2.58	2.37	0.48
(q3-q1)/(2M), %	9.3	2.5	6.25	8.33	2.42	1.45	2.53	1.21	0.33

* an average value for each specimen, it was measured in 5 points

The whole production of 816 collecting electrodes from 7 heats and 12 rolls must show variation between material properties. TABLE 1 shows that thickness of the sheet is almost constant (coefficient of variation is only 0.43%, although few specimen are less than 1.5 mm thick, rolls r3 and r7 are the thinnest). TABLE 2 indicates that content of phosphorus and sulphur differs more than manganese and carbon. Referring to mechanical properties yield strength ranges more than tensile strength, the latter differs similarly to elongation and Vickers hardness.

2.2. Geometrical features of end products

Collecting electrodes must be manufactured according to a project, and finally controlled. Only these items which meet the shape requirement are accepted for sale. In Fig. 3 a drawing indicating what features of the product are measured and controlled is presented. There are 12 shape parameters (Fig. 1, 4) and length. In order to show their variation, four variables changing below 1% were omitted, namely height at side A and B, length and width. The rest was presented in TABLE 3. The basic measures of descriptive statistics concerning the measured geometrical quantities are collected in TABLE 4. As these parameters are

measured directly, some of them are length dependent. So more accurate parameter than alone mean or standard variation is their percentage ratio.

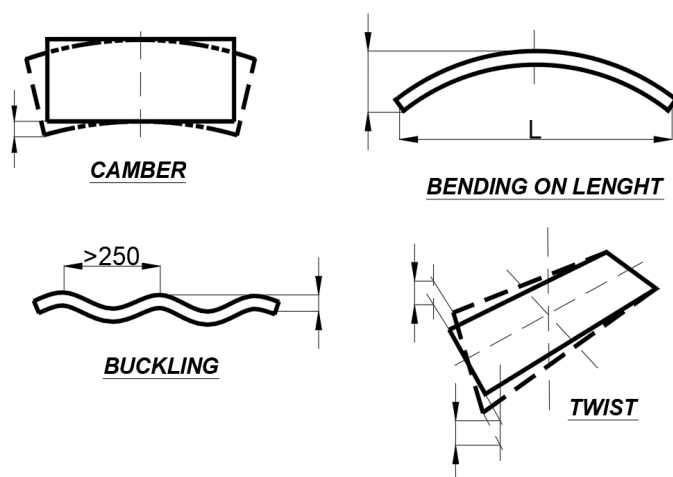

Fig. 4. Schematic presentation of buckling, bending, camber and twist for the collecting electrodes

As shown in the previous chapter, rolls are described using individual properties referring to chemical composition, thick-

TABLE 3

Percentage ratio of standard variation and mean for length and not length dependent geometric tolerance

Roll	Ac	Bc	C1	C2	E1	E2	Buckling	Twist	Camber
	Not length dependent								
r1	2.70	5.85	1.55	2.56	1.87	1.19	6.15	2.45	4.2
r2	2.19	2.38	3.0	3.0	3.28	2.97	5.61	0.97	4.7
r3	5.28	5.10	2.31	3.44	3.17	1.65	10.6	3.55	5.3
r4	4.83	5.58	3.04	3.44	2.60	2.94	13.9	12.0	6.5
r5	4.60	7.24	2.29	2.86	2.99	2.46	7.9	23.7	11.45
r6	6.27	13.29	3.33	3.54	3.06	2.21	5.0	28.5	6.6
r7	25.73	19.31	2.44	3.06	3.60	1.78	40.6	27.2	26.55
r8	8.25	2.28	2.43	3.82	2.23	1.37	4.4	20.6	4.7
r9	6.63	5.24	2.25	3.25	2.81	2.0	8.9	9.8	14.4
r10	6.11	6.15	1.99	3.48	3.73	3.65	21.0	7.8	8.9
r11	10.28	7.32	2.84	3.6	3.51	2.7	4.2	4.75	6.2
r12	27.76	20.69	2.77	3.95	3.54	2.4	20.1	9.54	9.11

TABLE 4

Statistical analysis of geometric tolerance from all rolls (134 specimens)

Statistical measures	Ac	Bc	C1	C2	E1	E2	Buckling
Mean x	2.66	2.64	28.71	28.89	29.11	28.75	1.575
Sample standard deviation s	0.596	0.567	0.754	0.937	0.886	0.756	0.431
Median M	2.9	2.9	28.8	29	29.45	28.8	1.45
Minimum	1	1	27	27	27	26.6	0.8
Maximum	3.5	3.5	30	30	30	30	2.7
Skewness	-1.126	-0.978	-0.452	-0.476	-0.898	-0.404	0.292
Kurtosis	0.006	-0.481	-0.4	-0.962	-0.339	-0.293	-1.264
Quartile q1	2.325	2.35	28.3	28.2	28.5	28.3	1.2
Quartile q3	3	3	29.2	29.8	29.8	29.3	2.0
s/x, %	22.34	21.44	2.62	3.3	3.04	2.63	27.34
(q3-q1)/(2*M), %	11.64	11.21	1.56	2.9	2.21	1.74	27.59

ness, and mechanics. So the statistical analyses of shape were presented for each roll and finally the whole production.

The largest variation of shape parameters shown in TABLE 3 occurred for roll 7. It is the roll with the thinnest sheet TABLE 1. Although roll 3 has the same minimum thickness this relation is not observed. The normality of analyzed data was controlled by Shapiro-Wilk and Kolmogorov tests. It was stated that not all results of the examined geometrical features came from a normally distributed population

3. Results and discussion

Authors do not know any publication which describes this profile as an end-product, and analyses its geometric features in relation to the chemical composition and mechanical properties of technological charge. A section similar to our Sigma profile of the collecting electrode, namely a trapezoidal one, was analysed in a paper from 2018 [9]. Measurements were carried out in real production conditions. Three widths of a sheet were formed: 950, 1100, and 1250 mm; and three thickness: 0.5, 0.6 and 0.7 mm in 20 stations, each sheet was 2.5 m long. Three materials were studied: steel DX5D, DX 5D, and aluminium Al 99.5. Authors measured rollers load and their deflection. The production line was equipped with strain gauges, and proper data acquisition system. As variable input for the numerical analysis were chosen tensile strength, sheet thickness and width. As constant input for this analysis were selected: forming machine, rollers geometry, lubrication, radius of roller, bending angle, stiffness of the rolls. As output results were chosen: measured indirectly forced and directly strains in various points. Authors proposed a polynomial formula, which transformed changes of input variables and constants into selected results. This statistical model was validated and lead to in-depth conclusion on the required modernization.

3.1. Relation between chemical composition of technological charge and geometry of end-product

Professional, commercial code Minitab was used in order to carry out a multiple regression study of the gathered data. The sought-for functions were determined by means of its optimisation algorithms. In case of the analysed geometrical features (TABLE 3, 4) four predictors, namely the elements of the steel

sheets chemical composition (C, Mn, P, S), were chosen as describing variables. The determined regression equations were presented in TABLE 5. In order to compare the found regression equations, the adjusted R^2 coefficient was implemented. Minitab tried different forms of regression equations and calculated their confidence level. They were accepted if were statistically important at p-value.

For twist and buckling the found regression models turned out to be non linear. In addition, there was an effect of a two-factor interaction between individual explanatory variables, an example is shown in Fig. 4. In both cases, the interactions turned out to be statistically significant (the lines on the graph intersect). The graphs shown illustrate the effect of carbon variability on the dependent variable (twist) depending on the range of variability of other variables in the analyzed models. With a carbon content of about 0.046 %, there is a change in the influence of the elements that create the effect of interaction. With the minimum content of phosphorus, an increase in the carbon content causes a simultaneous increase in the average twist of the profile of the electrode, while at the maximum content of this alloying element, the increase in carbon content reduces the average value of twisting of the electrode profile. The graph of the interaction of carbon and sulphur obtained by predicting the buckling of the profile surface is similar and should be interpreted analogously. In both analyzed cases, at the maximum carbon content of $C = 0.058\%$, the spread of the performance tolerance value is greater than for the minimum value of C.

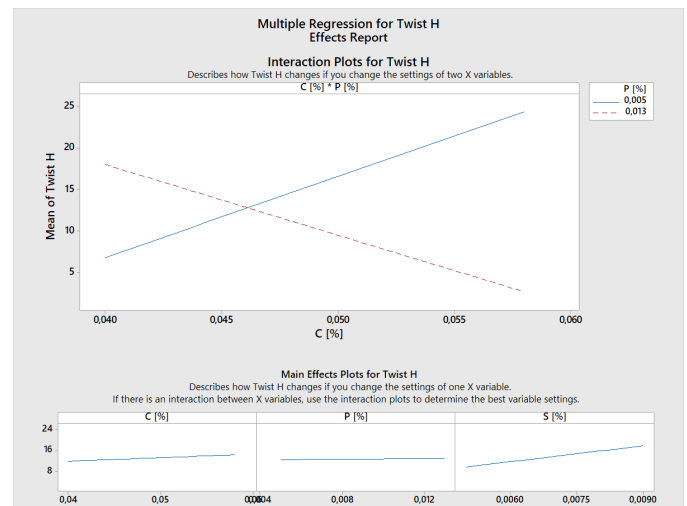

Fig. 5. Interaction between carbon and phosphorus contents in the steel grade and their influence on twist

TABLE 5

Regression analysis between chemical composition of technological charge of DC01 steel grade and geometric features of end-product

Geometric feature/Regression equation	Adjusted R^2 [%]
Bend Ac = $-4.017 + 50.56 \%C + 21.78 \%Mn$	45.3
Bend Bc = $-3.673 + 51.95 \%C + 19.68 \%Mn$	45.06
Twist H = $-98.5 + 2124 \%C + 10565 \%P + 2041 \%S - 229005 \%C*\%P$	66.2
Camber = $-1.103 + 15.46 \%Mn + 73.5 \%P$	38.6
Buckling = $-17.75 + 513.8 \%C + 2598 \%S + 98082 \%S^2 + 84670 \%C*\%S$	41.7

Regression analysis between mechanical properties of technological charge of DC01 steel grade and geometric features of end-product

Geometric features/Regression equation	Adjusted R ² [%]
Bend Ac = $-9189 + 34.28 R_{p0.2} + 12.764 R_m + 91.42 A_{80} + 25.03 HV10 + 0.03203 R_{p0.2}^2 + 0.333 A_{80}^2 - 0.01438 HV10^2 - 0.05554 R_{p0.2} * R_m - 0.5106 R_{p0.2} * A_{80} - 0.09703 R_{p0.2} * HV10$	83.7
Bend Bc = $-8667 + 27.46 R_{p0.2} + 16.52 R_m + 93.52 A_{80} + 17.36 HV10 + 0.02361 R_{p0.2}^2 - 0.01744 R_m^2 - 0.03018 HV10^2 - 0.03534 R_{p0.2} * R_m - 0.4121 R_{p0.2} * A_{80} - 0.09610 R_{p0.2} * HV10 + 0.03217 R_m * HV10$	86.2
Twist H = $-45647 + 152.4 R_{p0.2} + 78.7 R_m + 342.7 A_{80} + 149.6 HV10 + 0.1329 R_{p0.2}^2 - 0.0498 R_m^2 + 3.115 A_{80}^2 - 0.1864 HV10^2 - 0.1940 R_{p0.2} * R_m - 2.518 R_{p0.2} * A_{80} - 0.4729 R_{p0.2} * HV10$	80.0
Camber K = $-56069 - 1.374 R_{p0.2} + 10.03 R_m + 710.4 A_{80} + 728.7 HV10 - 0.13364 R_m^2 - 1.348 HV10^2 + 0.11311 R_{p0.2} * R_m - 1.0124 R_{p0.2} * A_{80} + 1.953 R_m * A_{80} - 0.1450 R_m * HV10 - 10.100 A_{80} * HV10$	83.7
Buckling = $-2417 - 0.807 R_{p0.2} + 13.300 R_m + 12.35 A_{80} - 0.0494 HV10 - 0.02201 R_m^2 + 0.008151 R_{p0.2} * R_m - 0.05431 R_{p0.2} * A_{80}$	69.2

3.2. Relation between mechanical properties of technological charge and geometry of end-product

This analysis was aimed at understanding the effect of regressors (independent variables) representing the mechanical properties of cold-rolled steel strip on the geometric tolerances of the finished product. The same calculation procedure was used as in the case of the study of the influence of chemical composition on selected geometric features of the electrodes. Individual regression models are listed in TABLE 6.

For all analysed models, a high value of the corrected coefficient of determination $R^2 > 70\%$ was obtained, which, according to literature data, indicates a good matching of the regression function with empirical data and high predictive capacity. The variability of the dependent variables was explained by a set of explanatory variables in the range of 69-86%. The limit value of the coefficient of determination $R^2 > (70\%)$ given in the literature cannot be a reference, especially when analyzing cross-sectional process data (different heats of steel strip for one production order). All values of the coefficient of determination are statistically significant.

Small discrepancies between the values of the coefficient of determination and the corrected coefficient of determination suggest that the variables adopted for the models are optimally selected. It should also be mentioned that regression models were estimated being aware of the low coefficient of variation of explanatory variables, representing the mechanical properties of the technological input. Building regression models for empirical data from the production process was guided by the desire to achieve cognitive goals. Each of the five obtained models of multiple regression showed a non-linear form compared to the approximation of the classical method of least squares. A significant increase in the adjusted coefficient of determination was observed (the largest for buckling, 6 times). In the obtained regression models, there were effects of interaction between explanatory variables (simultaneous influence of several factors together on the dependent variable). All interactions should be considered statistically significant (the lines on the graphs intersect). On the exemplary graph in Fig. 6, the influence of yield strength variability on the dependent variable bend "Ac"

depending on the range of variability of other predictors in the analyzed models was illustrated. At $R_{p0.2}$ around 224-226 MPa (yield strength and hardness interaction) there is a change in the influence of the mechanical properties that create the effect of the interaction. For other cases, the intersection point of the graphs is shifted to the right by about 4-6 MPa. The relationships between variables are monotonic (they do not grow or decrease at one pace). This is most evident in the case of estimation of bend Ac, Bc regression models and twist of the electrode profile.

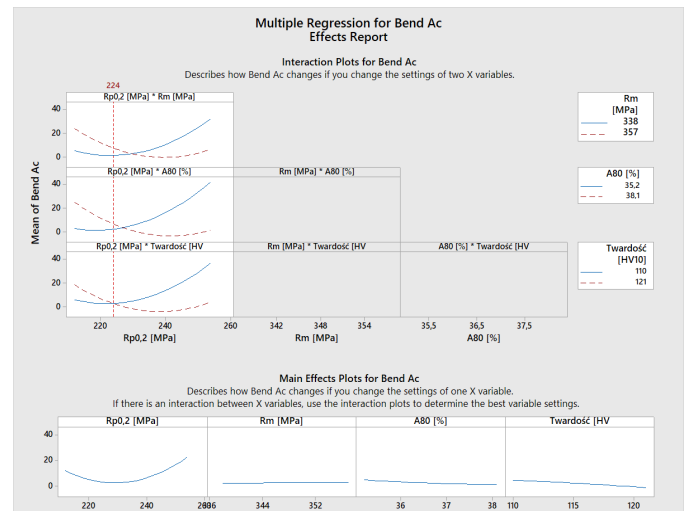

Fig. 6. Interaction between analysed mechanical properties of the steel sheet and their influence on bend Ac

For the specified regression models, the strongest nonlinear relationship was shown by the yield strength. With a minimum setting of R_m , A_{80} and hardness, an increase in yield strength causes a simultaneous increase in the average value of the profile bend and its twist, while at the maximum setting value of this variable, an increase in the yield strength reduces the average value of the discussed tolerances. For the maximum yield point value, the performance tolerance range is greater than for the minimum value. Additionally, in addition, in the model estimating the bending of Bc, there is a weak interaction of R_m and hardness.

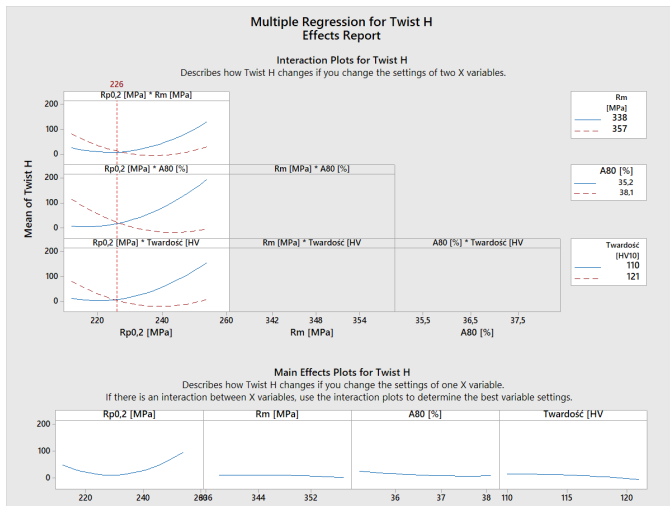

Fig. 7. Interaction between analysed mechanical properties of the steel sheet and their influence on twist

In the case of a multivariate model estimating camber of the electrode the largest number of interactions within the explanatory variables was obtained. In two cases ($R_{p0.2} * R_m$) and ($R_m * \text{Hardness}$), the interactive compounds were found to be weak. The most pronounced is the effect of the interaction of elongation and hardness and tensile strength and elongation on the average value of the explanatory variable. In the analyzed regression model, the greatest nonlinear dependence showed the hardness of the technological charge. The relationships between the mechanical properties for a regression model estimating electrode surface buckling are shown in Fig. 8. It can be noted that the interactions ($R_{p0.2} * R_m$) and ($R_{p0.2} * A_{80}$) occurring in this model are characterized by a linear relationship.

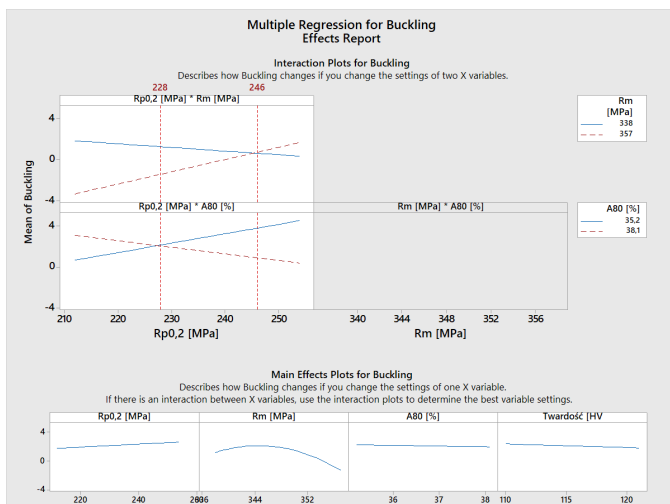

Fig. 8. Interaction between analysed mechanical properties of the steel sheet and their influence on buckling

For the minimum value R_m , an increase in the yield strength value reduces the buckling of the surface of the electrode, while for the maximum value R_m with an increase in $R_{p0.2}$, the analyzed geometric tolerance also increases. At a value of $R_{p0.2}$ of

approximately around 228 MPa, there is a change in the influence of the mechanical properties that create the interaction on the mean buckling value of the electrode profile. The opposite situation can be observed for interactions ($R_{p0.2} * A_{80}$), for which the change in the influence of a pair of variables is visible from the value of $R_{p0.2}$ about 246 MPa. The strongest nonlinear relationship in the analyzed regression model was shown by tensile strength.

4. Conclusions

The statistical analyses carried out, covering the technological change, brought a high cognitive value of the impact of individual components on the permissible tolerances of the final product.

The empirical data used for the analysis were of a process, cross-sectional nature, which all the more prompted to learn about the interdependencies and functional dependencies within the explanatory variables representing the chemical composition and mechanical properties of the cold-rolled steel strip DC01.

- The greatest variation in the properties of the technological charge was demonstrated for phosphorus, sulphur content and yield strength.
- The obtained multiple regression models confirm that individual functional compounds take a nonlinear form. In these cases, the effects of interaction between the variables have been determined.
- All the analysed geometric features depend on all the analysed mechanical properties. The one including the smallest number of interactions is relation of buckling, whilst the other are equally complex.

The test material can be a comparative basis for other steel strip grades used for the production of collecting electrodes, e.g. hot-rolled steel strips, weathering steel strips such as Corten A and stainless steel strips.

Acknowledgements

Authors would like to acknowledge the industrial partner, Valmet Technologies OY, Finland, for material data and geometrical measurements of the end-products.

REFERENCES

- [1] W. Cha, N. Kim, International Journal of Precision Engineering and Manufacturing **14** (9) 1527-1533 (2013). DOI: <https://doi.org/10.1007/s12541-013-0206-8>
- [2] M.M. Kasaei, H.M. Naeini, G.H. Liaghat, C.M.A. Silva, The Journal of Strain Analysis for Engineering Design 1-14 (2015).
- [3] R. Safdarian, H.M. Naeini, Thin-Walled Structures **92**, 130-136 (2015).

- [4] Y. Zhang, H.-P. Nguyen, D.-W. Jung, *International Journal of Mechanical Engineering and Robotics Research* **5** (4), 272-275 (2016).
- [5] Y. Wang, X. Xu, B. Ren, J. Liu, R. Zhao, *Applied Sciences* **11** (17), 7852 (2021). DOI: <https://doi.org/10.3390/app11177852>
- [6] C. Liang, S. Li, J. Liang, J. Li, *Metals* **12** (1), 53 (2022). DOI: <https://doi.org/10.3390/met12010053>
- [7] PN-EN 10130:1999. Wyroby płaskie walcowane na zimno ze stali niskowęglowych do obróbki plastycznej na zimno. Techniczne warunki dostawy.
- [8] PN-EN 10131:2006. Wyroby płaskie ze stali niskowęglowych i stali o podwyższonej granicy plastyczności walcowane na zimno, niepowlekane i powlekane elektrolitycznie powłoką cynkową lub cynkowo-niklową, przeznaczone do obróbki plastycznej na zimno. Tolerancje wymiarów i kształtu.
- [9] M. Jurkovic, Z. Jurkovic, S. Buljan, M. Obada, *Advances in Production Engineering & Management* **13** (1), 57-68 (2018). DOI: <https://doi.org/10.14743/apem2018.1.273>