

INFLUENCE OF PARTICLE SIZES AND VOLUME FRACTIONS ON FATIGUE CRACK GROWTH RATES OF AEROSPACE Al-ALLOYS COMPOSITES

Recently, the need to develop fuel efficient transport systems has led to the development of a range of materials of low density, high stiffness and high strength each can be made at a reasonable cost. The aluminium based alloys are particularly important because of their improved mechanical, physical and technical properties. Fatigue failures have been recognised since the early days of the industrial revolution. Fatigue response of most of materials is related with the microstructural variations in the structure. Hence, in this study, influence of particle size and volume fractions on fatigue properties of Al-alloy composites was investigated. It was found that particle size and volume fraction of reinforcement particles play significant role on fatigue propagation rates, stress intensity threshold values, crack tip opening distance and crack tip plastic zone sizes.

Keywords: Fatigue crack propagation; particle size; volume fraction; Al-alloy composites

1. Introduction

Over the last fifty years, a variety of composite materials has been developed by using conventional and novel processing techniques. The discontinuous metal matrix composites with short fibre (whisker) or particulate reinforcements have attracted the interest of scientist and engineers, because of their attractive physical, mechanical and fatigue properties at a reasonable cost. Metal Matrix Composites (MMC) based on particulate reinforcements are especially preferred, since in addition to the financial benefit they have properties that are more isotropic than the continuous reinforced counterparts. They are of particular interest for automotive, defence, sporting goods, electronic industries and more extensively in aerospace industries [1]. They can be produced easily by using conventional metallurgical techniques, such as, powder metallurgy (PM), direct casting, forging and extrusion etc. each of these processing methods results in significantly different mechanical, physical and technological properties. The PM processing route is generally superior since it offers a number of advantages, such as better interfacial bonding between matrix and reinforcement particles, better densification and more uniform reinforcement distribution than casting routes.

The fatigue response of Al-based composites has been received reasonable attention in literature. The tensile responses [2-4], high cycle fatigue properties [5,6], low cycle fatigue

properties [7,8], notch behaviour and fatigue life predictions [9-13] of Al-SiC_p composites were extensively investigated. The fatigue response of the MMCs has been influenced by the type of matrix alloy, type of reinforcement (continuous, whisker or particle), composition of reinforcement, heat treatment, processing methods and volume fraction (V_f) and size of reinforcement (P_z) [1]. Unfortunately, the presence of hard and brittle ceramic reinforcements reduces the monotonic ductility, fatigue crack growth resistance at high growth rates and fracture toughness compared with the monolithic Al-alloy. These properties are crucial for component reliability and design in many industrial applications. It is important to noted that there is always the possibility that complex and highly stressed structures can contain flaws. The fatigue life in such situations will depend on the rate of crack propagation from these inherent flaws to a critical size for catastrophic failure. Many failures of structural parts in service occur under various loading and environmental conditions where characteristics of reinforcements may change the fatigue crack growth rates and crack initiation. Although, the tensile behaviour and some fatigue of this composites has been studied widely [1-13], the information available on their fatigue crack propagation is limited. In general, the role of the reinforcements particles are well understood in many studies, but there is no clear understanding of the effects of reinforcement particle size and volume fraction on the fatigue crack

¹ DUZCE UNIVERSITY, FACULTY OF ENGINEERING, DEPARTMENT OF MECHANICAL ENG. 81620, DUZCE

* Corresponding author: ilyasuygur@duzce.edu.tr



propagation rates of these composites. Thus, this particular research is mainly aimed at investigating the effect of P_z and V_f on the fatigue response of 2124 /SiC_p composites in naturally aged (T4) conditions.

2. Materials and experimental procedures

The materials were commercially available MMCs consisting of 2124 Al-alloys (Al-Cu-Mg-Mn) with 17 and 25 vol% of SiC_p. All of the materials were produced by Aerospace Composite Materials (U.K.) which were labelled as AMC217 (17vol% 2-3 μm SiC_p), AMC225 (25vol% 2-3 μm SiC_p), LAMC225 (25vol% 10-20 μm SiC_p) using the PM processing. Prior to machining process, a solution treatment was applied at 505°C for 1 h, followed by cold water quenching, after that natural ageing (T4) at room temperatures. The alloy composition, particle size detection and distribution and tensile response of these composites were extensively investigated and discussed elsewhere [2].

The fatigue crack propagation evaluation, a 10×10 mm ‘Corner Crack’ (CC10) test piece design was shown in Fig. 1. The probe wire positions for the DC Potential Drop (PD) is also shown in same figure. A crack was initiated from an edge slit 0.25 mm deep. Pulsed Direct Current (DC) potential drop systems were used to monitor crack growth. At predetermined stages of the test a constant DC power supply delivered a 50 A, two pulse to the specimen for 2 s while the fatigue cycles were held at 75% of the peak load. During this period the potential drop was measured across the crack. Potential drop data were converted to length, and Fatigue Crack Growth Rates (FCGR) assessed as a function of applied Stress Intensity Range ΔK [13]. Calibration trials and comparisons with data obtained using optical and DC potential drop systems have been established that the pulsed DC system has no measurable effect on the rate of crack propagation in these materials. DC PD monitoring was carried out using 0.3 mm diameter, insulated probe wires which were attached to the specimen by means of a 50 watt spot weld (Hughes Aircraft Company). The welding current was set 2-2.5 A. Typical cyclic frequency was 55 Hz, R ratio was $R = 0.1$ and 1 Hz sinewave form was applied to all samples. All tests were performed under constant amplitude load control ESH Tension Torsion Fatigue using test machines.

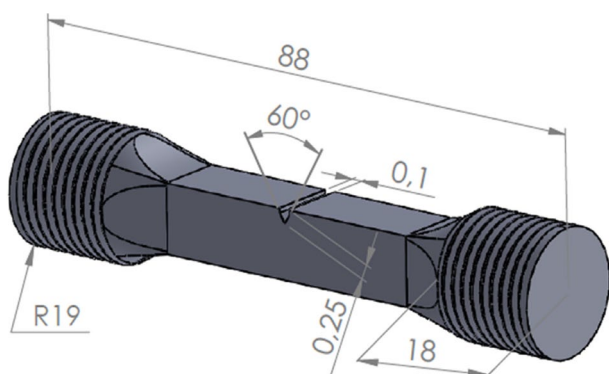

Fig. 1. Fatigue crack propagation test sample CC10

Typical microstructure and crack growing from the starter slit in a CC10 sample was shown in Fig. 2. Plastic replicas were used to measure final crack length with the stress held at a near max. level.



Fig. 2. Optical crack profile in LAMC225 MMC material at 225 MPa ($\times 100$). 1.8 mm total crack length. Crack propagated from left to right

3. Results and discussions

The influence of V_f and P_z of reinforcement particles on the FCGR was studied for CC10 samples using DC PD monitoring, optical microscopy and acetate replicas. The DC PD results were analysed according to standard calibration procedures [1,12,13]. The PD response of Ti-alloys has been characterised simply on the basis of measured slit and reference voltages. However DC PD signals for Al-alloys are very small due to their good conductivity. Thus the reference and slit voltage correction techniques induced considerable scatter, making it more difficult to interpret the FCGR data. For this reason, only direct measurement of reference voltage was used to calculate the crack length and FCGR. The measurements of the crack length by optical microscopy and replicas confirmed the validity of these PD measurements. Typical crack length measurement and FCGR results were illustrated for both measurement as shown in Figs. 3a and 3b.

The FCGR (da/dN) for three Al-alloy composites are shown as a function of ΔK in Fig. 4. Two distinct regimes of behaviour can be identified. At low ΔK levels below about 10^{-8} and 10^{-9} m/cycle, FCGR in the AMC217 were significantly faster than for AMC225 and LAMC225. Estimates of the apparent threshold stress intensity factor (ΔK_{th}) suggest that ΔK_{th} is 5.3 MPa $\sqrt{\text{m}}$ for AMC225, but $\Delta K_{th} = 4.1$ MPa $\sqrt{\text{m}}$ for AMC217. There is an apparent increase in this pseudo ΔK_{th} of about 18 % between the LAMC225 and AMC225 materials. This indicates that V_f and P_z play a crucial role on the early stages of crack growth. However, with increasing ΔK (Paris regime) this trend is reversed and FCGR become faster in AMC225 compared with AMC217. Even so LAMC225 had the slowest FCGR across all values of ΔK . Similar behaviour and threshold values have been reported for Al-alloys and its composites [14-18]. The reason for the low ΔK_{th} values was attributed to crack closure levels which were four times higher for the LAMC225 compared with the AMC225 composites.

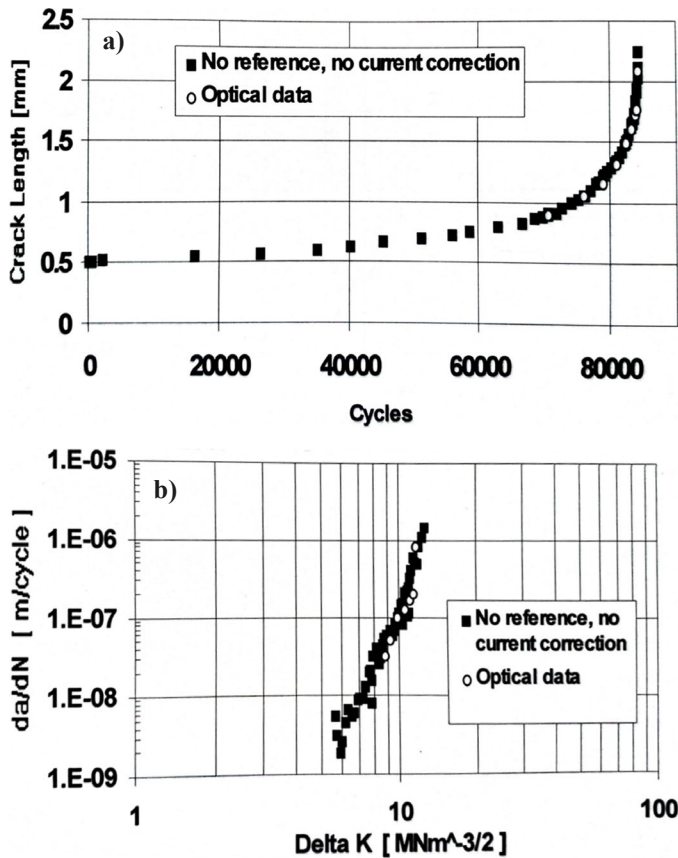

Fig. 3. a) Crack length against cycles for AMC225 using direct DC PD voltage without any correction and optical data. b) The FCGR (da/dN) against stress intensity range (ΔK) for the same sample

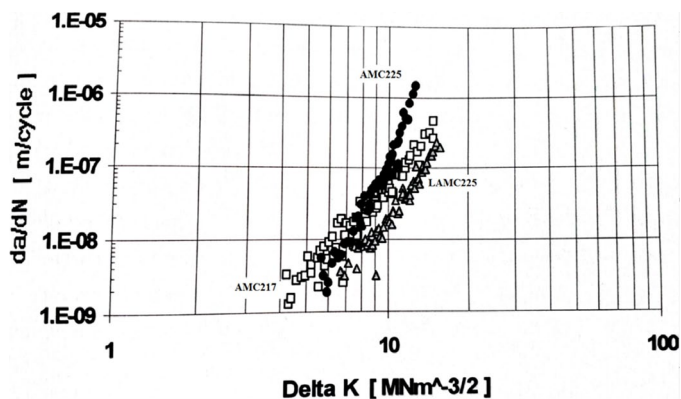

Fig. 4. The FCGR (da/dN) as a function of ΔK for AMC217, AMC225 and LAMC225 composites

The Paris law coefficients C and m in the $da/dN = C \Delta K^m$ relationship were determined by linear regression of the $\log(da/dN)$ vs $\log(\Delta K)$ graphs as given in TABLE 1. The C and m values were significantly altered by reinforcement content and size. The values are close to those reported for similar composites, consisting of the 2024 alloy with 15 and 25 vol% SiC_p [19]. Comparison is also made with composites based on 2024 Al-alloys T4 state (see TABLE 1). It is worth noting that the composition of the composite based on 2024 Al-alloy and average P_z was similar to the present study on AMC217 and AMC225. Hence very similar FCGR, and Paris law expo-

nents were measured. It was reported that the resulting FCGR curves show specific changes in the location of transition points and adjacent slopes for changes in alloy composition and heat treatments for various materials [20].

TABLE 1

Paris Law parameters for aluminium alloy composites

Materials	m	C
AMC217	5.4	$8.7 \cdot 10^{-13}$
AMC225	5.8	$5 \cdot 10^{-13}$
LAMC225	4.9	$6 \cdot 10^{-13}$
2024 15 vol% SiC_p [19]	4.4	$9 \cdot 10^{-13}$
2024 25 vol% SiC_p [19]	5.3	$8.1 \cdot 10^{-13}$

For Al-alloy / SiC_p [12,21-22] at low ΔK_{th} levels, there is a strong tendency for crack arrest and deflection around the reinforcement particles. This process is most prominent for coarse SiC_p sizes. However, some closure still occurs at low ΔK levels in fine particulate composites, because of the limited crack tip opening displacement (CTOD). Roughness-induced crack closure is most effective at low ΔK ranges when CTOD is comparable with surface asperity sizes. It is also more important at low load ratios and where there is a crack deflection mechanism. Although CTOD measurements have not been performed in this study, the magnitude of CTOD can be calculated from [23];

$$\text{CTOD} = 0.5 (\Delta K)^2 / s_{cyc,yield} \cdot E \quad (1)$$

Where $s_{cyc,yield}$ is the cyclic yield strength, E is the elastic modulus of the composites.

The equation gives a CTOD value of $0.38 \mu\text{m}$ for AMC217 composite at the $\Delta K = 6 \text{ MPa}\sqrt{\text{m}}$ level. This is 27% higher compared to AMC225 MMC. A CTOD value is $0.41 \mu\text{m}$ for LAMC217 composite for a given ΔK . This is also approximately 27% higher than in the case of LAMC225 MMC. Since differences in yield behaviour have been measured according to the volume fraction [2], this infers that crack tip closure should be less prevalent in the lower volume fraction reinforced variants due to a lower $s_{cyc,yield}$. The differences in CTOD may also account for what appears to be a lower ΔK_{th} in the AMC217 than AMC225 composite. However, crack closure effects diminish at higher ΔK levels (typically higher than $\Delta K = 10 \text{ MPa}\sqrt{\text{m}}$) once CTOD becomes comparable in size to the average particle size. At this stage the FCGR increased slightly in AMC225 compared with AMC217 (Fig.4). The increased rates may also be attributed to the onset of unstable crack growth as K_{max} approaches the fracture toughness. This view is consistent with the observation that the toughness is lower in AMC225 material. In the coarse reinforced particulate composite LAMC225 crack closure remains effective, even at high ΔK levels, because CTOD is always smaller than the average particle size. This is consistent with the lowest FCGR and highest apparent ΔK_{th} values occurring in the LAMC225 composite. Similar effects due to P_z and V_f on FCGR have been reported by other researchers for various types of Al-alloy composites [17, 22, 24].

Another factor that influences FCGR and ΔK_{th} values is the size of plastic zone at the crack tip [25]. The diameter of the plastic zone under the plain stress condition can be written;

$$r_p = 1/\Pi (K_I/s_{yield})^2 \quad (2)$$

According to the above equation the plastic zone size is 8.5, 13 and 18 μm for the AMC217, AMC225 and LAMC225 composites, respectively, at typical ΔK_{th} values. The plastic zone in the AMC217 composite will incorporate fewer particles than in the AMC225 composite for example. Thus, particle-crack interactions like; crack deflection (Fig. 5), crack trapping (Fig. 6) crack closure should be less significant and thereby contribute to an increased FCGR in AMC217. However, the size of plastic zone is 77 μm and 67 μm for AMC217 and AMC225 composites respectively at $\Delta K = 12 \text{ MPa}\sqrt{\text{m}}$. At this stage, one might expect similar growth kinetics on the basis of the plastic zone argument.

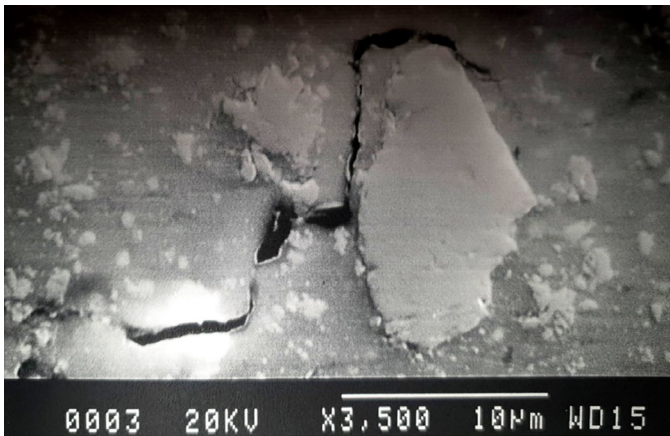

Fig. 5. Crack tip deflection around the Large SiC particles

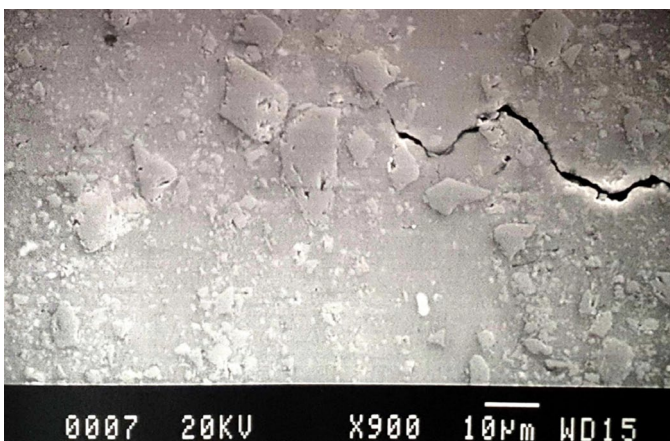

Fig. 6. SEM micrograph of crack trapping at the large SiC particles

The average measured Paris Law exponent “ m ” is defined in Table 1. However, at fast FCGR the slope in the growth rates data increases. This increase in the slope may be associated with void nucleation and growth. This is confirmed by the micrograph (Fig. 7) taken as growth rates approach final failure showing many ductile dimples. Thus rapid void formation ahead of a moving crack front accelerates the overall crack growth

rates. This mechanism will be particularly favoured in composites containing high volume fraction of particles which tend to promote void formation. Similarly, in the fast-fracture region, the ductile fracture mechanism exhibiting voids formation and coalescence resulted in a coarse fracture surface morphology. Consequently, a high fractal dimension of the crack is expected for this fast fracture in AISI 410 steel [26].

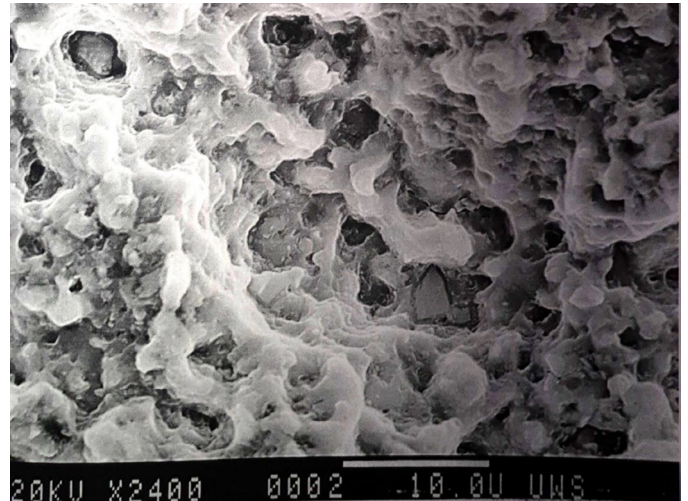

Fig. 7. Fast fracture features in AMC225

4. Conclusions

This study analysed the influence of P_z and V_f on the fatigue response of 2124 /SiC_p composites in naturally aged (T4) conditions and primary conclusions of the paper may be summarised as follows:

1. AC PD technique and polymer replicas with optical microscopy can be easily used to measure and calculate the crack length and FCGR for Al-alloy composites.
2. The V_f and P_z play a crucial role on the early stages of crack growth. Stress intensity threshold values; $\Delta K_{th} = 4.1 \text{ MPa}\sqrt{\text{m}}$ for AMC217, $\Delta K_{th} = 5.3 \text{ MPa}\sqrt{\text{m}}$ for AMC225, $\Delta K_{th} = 6.2 \text{ MPa}\sqrt{\text{m}}$ for LAMC225.
3. Crack tip plastic zone size and crack opening distance were also strongly affected by the V_f and P_z .
4. The Paris law coefficients C and m in the $da/dN = C\Delta K^m$ relationship were also influenced by the V_f and P_z . In general both values increased by increasing volume fraction and reduced by increasing particle sizes for these composites.
5. The V_f and P_z play an important role for void formation and and coalescence in the microstructure.

Acknowledgement

The Author thanks Prof. Dr. W. J. Evans and Prof. Dr. Martin Bache at the University of Wales, Swansea for their great assistance and help. The work described here was carried out in the Department of Materials Engineering at University of Wales, Swansea.

REFERENCES

- [1] I. Uygur, PhD thesis, Environmentally assisted fatigue response of Al-Cu-Mg-Mn with SiC particulate metal matrix composites, University of Wales, SWANSEA, U.K. (1999).
- [2] I. Uygur, *Iranian J. Sci. & Techn.* **B28** (B2), 239-248 (2004).
- [3] I. Uygur, H. Saruhan, *SDU Int. J. of Techn. Sci.* **8** (1), 167-174 (2004) in Turkish.
- [4] S. Kumar, R. Kumar, K.K. Goyal, N. Sharma, *Materialstodays: Proceedings* **63**, 395-399 (2022).
- [5] I. Uygur, W.J. Evans, M. Bache, B. Gulenc, *Metallofiz. Nove. Technol.* **26** (7), 927-939 (2004).
- [6] J. Xia, J.J. Lewandowski, M.A. Willard, *Mater. Sci. and Eng. A* **770** (1), 138518 (2020).
- [7] I. Uygur, M.K. Kulekci, *Turkish J. of Eng. & Env. Sci.* **26** (3), 265-274 (2002).
- [8] Q. Zhang, D.L. Chen, *Int. J. of Fatigue* **27** (4), 417-427 (2005).
- [9] I. Uygur, *Arch. Metall. Mater.* **56** (1), 109-115 (2011).
- [10] Y. Wang, H. Ma, Y. Zhang, *Eng. Frac. Mech.* In Press 108947 (2022).
- [11] I. Uygur, A. Cicek, E. Toklu, R. Kara, S. Saridemir, *Arch. Metall. Mater.* **59** (1), 97-103 (2014).
- [12] M.R. Bache, W.J. Evans, I. Uygur, *Mater. Sci. and Tech.* **14** (2), 1065-1069 (1998).
- [13] M.R. Bache, W.J. Evans, A.J. Shakesheff, J. Shields, I. Uygur, *Mater. Sci. and Tech.* **16** (2), 825-830 (2000).
- [14] S. Bruzzi, P.E. McHugh, *Int. J. of Fatigue* **26**, 795-804 (2004).
- [15] A.A. Ikbali, Y. Arai, W. Araki, *Trans. Nonferrous Met. Soc. China* **24**, 1-13 (2014).
- [16] N. Chawla, V.V. Ganesh, *Int. J. of Fatigue* **32**, 856-863 (2010).
- [17] B.F. Jogi, P.K. Brahmankar, V.S. Nanda, R.C. Prasad, *J. of Mater. Proces. Tech.* **2001**, 380-384 (2008).
- [18] O. Botstein, R. Arone, B. Shpigler, *Mater. Sci. and Eng. A* **128** (1), 15-22 (1990).
- [19] D.L. Davidson, *Eng. Frac. Mech.* **33** (6), 965-977 (1990).
- [20] E. Amsterdam, J.W.E. Wiegman, M. Nawijin, J.T.M. De Hosson, *Int. J. of Fatigue* **161**, 106919 (2022).
- [21] J.K. Shang, W. Yu, R.O. Ritchie, *Mater. Sci. and Eng. A* **102** (2), 181-192 (1988).
- [22] J.K. Shang, R.O. Ritchie, *Acta Metall.* **37**, 2267-2278 (1989).
- [23] J.J. Bonnen, C.P. You, J.E. Allison, W.J. Jones, Fatigue behavior of discontinuously reinforced aluminum matrix composites, in *Proceed. Of 4 th Conf. "Fatigue90"*, Honolulu, (1990).
- [24] S. Suresh (Ed.), *Fatigue of materials*, Cambridge Uni. Press, Cambridge, (1991).
- [25] W. Yu, J. Wang, Z. Wang, Fatigue both SiCp Al-6061, in *Proceed. of 4 th Conf. "Fatigue90"*, Honolulu, (1990).
- [26] M.H. Hashimi, S.S.M. Kooloor, M.F. Abdul-Hamid, M.N. Tamin, *Eng. Frac. Mech.* **270**, 108589 (2022).