

O-H. KIM*, Y.C. KIM*[#]

AN ANALYSIS OF STRESS INTENSITY FACTOR DUE TO NORMAL STRESS FOR A CRACKED PLATE REINFORCED WITH A SHEET BY SEAM WELDING

ANALIZA WSPÓŁCZYNNIKA INTENSYWNOŚCI NAPRĘŻEŃ WYNIKAJĄCYCH Z PROSTOPADŁEGO NAPRĘŻENIA DLA PEKNIĘTEJ PŁYTY WZMOCNIONEJ PŁYTĄ PRZYSZAWANĄ SZWEM

It is essential in damage tolerance design to determine the stress intensity factor theoretically. The stress intensity factor for a cracked plate that is reinforced with a sheet by seam welding is determined theoretically and plotted as function of the seam welding location and stiffness ratio. The singular integral equation is derived based on the compatibility condition between the cracked plate and the reinforcement plate, and it is solved by means of Erdogan and Gupta's method. The theory is verified by comparing the results of the present analysis with those of a numerical analysis. The results from the present analysis show that the reinforcement effect improves as the welding line is situated closer to the crack and as the stiffness ratio of the cracked plate and the reinforcement plate increases.

Keywords: Stress intensity factor, Seam welding, Singular integral equation, Reinforcement effect

1. Introduction

As damage tolerance design is introduced in many different industries, including the construction of aircraft structures, research on crack behavior in reinforced plates has been extensively carried out. The damage tolerance approach assumes that cracks are initially present in the given structure. It is essential in damage tolerance design to determine the stress intensity factor theoretically.

Grief and Sanders solved the stresses of a reinforced cracked plate with a stringer by an integral equation method [1]. Liu and Ekvall investigated the variables that affect residual strength with a fracture mechanics experiment for a reinforced cracked plate with various reinforcement materials [2]. Kan and Ratwani determined the stress intensity factor for a cracked infinite plate bonded with infinite composite plate by adhesive showing non-linear behavior by an integral equation method of complex function [3].

In cases where the thin plate of a jet plane has flaws, it is reinforced by an attaching reinforcement plate [4]. With such reinforcement, it is necessary to estimate residual life. To this end, theoretical evaluation of the stress intensity factor is required. A thin reinforcement sheet is attached to a cracked plate by spot welding or seam welding. The authors theoretically solved the stress intensity factor for a cracked plate reinforced with a sheet by spot welding [5]. In the present study, the stress intensity factor for a cracked plate that is subjected to remote normal stress and reinforced with a sheet by symmetric seam welding parallel to the crack is determined theoretically.

2. Theory

2.1. Stress intensity factor of the reinforced cracked plate

It is considered that the cracked plate is reinforced with a sheet by seam welding symmetrically and remote uniform normal stress σ_0 is loaded, as in Fig. 1.

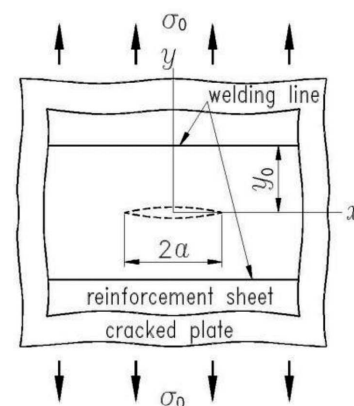

Fig. 1. The cracked plate reinforced with a sheet by seam welding

The cracked plate and the reinforcement sheet are assumed to be thin and homogeneous and they are in a two dimensional plane stress state. It is also assumed that there is no residual stress by seam welding and the reinforcement forces at bonding lines are applied uniformly through the thickness of two plates.

* DIVISION OF MECHANICAL & AUTOMOTIVE ENGINEERING, UFICT, KONGJU NATIONAL UNIVERSITY, 1223-24 CHEONANDAERO CHEONAN-SI CHUNGNAM-DO, 331-717, KOREA

[#] Corresponding author: yckim59@kongju.ac.kr

To simplify the problem, the welding zone is assumed to be a straight line.

Fig. 2 is a free body diagram of Fig. 1.

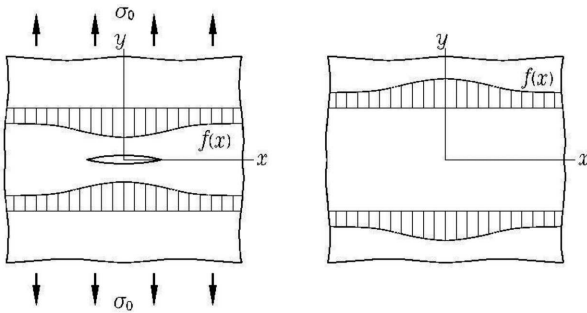

(a) Cracked plate (b) reinforcement sheet

Fig. 2. Free body diagram of the reinforced cracked plate

An unknown function $f(x)$ of the reinforcement force distribution in the y -direction is generated at the welding line.

The compatibility equation of displacements at the welding line is as follows.

$$v_c(x) - v_r(x) = 0 \tag{1}$$

where $v(x)$ is displacement in the y -direction and the subscripts c and r denote the cracked plate and the reinforcement sheet, respectively.

The displacement in the y -direction that is generated by applying concentrated forces Y at symmetric 4 points in the cracked plate is given by [5]

$$v = \frac{Y}{4\pi\mu t} \mathbf{H}(x, y; x_0, y_0, a)$$

$$\mathbf{H}(x, y; x_0, y_0, a) = \mathbf{I}(x, y; x_0, y_0) + \mathbf{J}(x, y; x_0, y_0, a) \tag{2}$$

where μ and t are the shear modulus and the thickness of the plate, respectively, a is a half crack length, and x_0, y_0 denote the location of loading point of force. $\mathbf{I}(x, y; x_0, y_0)$, $\mathbf{J}(x, y; x_0, y_0, a)$ are given as follows

$$\mathbf{I}(x, y; x_0, y_0) = \frac{2}{(\kappa + 1)} \left\{ \frac{\kappa}{2} \log \left| \frac{A_{14}A_{34}}{A_{12}A_{32}} \right| + \frac{\alpha_2^2}{A_{12}} + \frac{\alpha_2^2}{A_{32}} - \frac{\alpha_4^2}{A_{14}} - \frac{\alpha_4^2}{A_{34}} \right\}$$

$$\mathbf{J}(x, y; x_0, y_0, a)$$

$$= \frac{1}{(\kappa + 1)} \left[2yy_0 \left\{ -\frac{A'_{12}}{A_{12}^2} - \frac{A'_{14}}{A_{14}^2} - \frac{A'_{32}}{A_{32}^2} - \frac{A'_{34}}{A_{34}^2} + (T_1 - U_1) \frac{1}{rr_0} + (W_1 - V_1) \frac{r_0}{r} \right\} + \right. \\ \left. (\kappa + 1) \left\{ \frac{\alpha_4^2}{A_{14}} + \frac{\alpha_4^2}{A_{34}} - \frac{\alpha_2^2}{A_{12}} - \frac{\alpha_2^2}{A_{32}} + (Q_1 - P_1) y_0 \frac{r}{r_0} + (P_2 - Q_2) y \frac{r_0}{r} \right\} + \right. \\ \left. \frac{1}{4} (\kappa + 1)^2 \log \left| \frac{C(x_0, y_0)G(-x_0, y_0)}{B(x_0, -y_0)D(-x_0, -y_0)} \right| \right]$$

(3)

where

$$\alpha_1 = x - x_0, \alpha_2 = y - y_0, \alpha_3 = x + x_0, \alpha_4 = y + y_0$$

$$A_{ij} = \alpha_i^2 + \alpha_j^2, \quad A'_{ij} = \alpha_i^2 - \alpha_j^2 \quad (i=1,3 \text{ and } j=2,4)$$

$$r = \left[\left\{ (x - a)^2 + y^2 \right\} \left\{ (x + a)^2 + y^2 \right\} \right]^{1/4}$$

$$r_0 = \left[\left\{ (x_0 - a)^2 + y_0^2 \right\} \left\{ (x_0 + a)^2 + y_0^2 \right\} \right]^{1/4}$$

$$\Delta(\xi, \eta) = \{\Delta_L(\xi, \eta)\}^2 + \{\Delta_U(\xi, \eta)\}^2, \quad (\Delta = B, C, D, G)$$

$$\Delta_L(\xi, \eta) = x\xi - y\eta - \text{sig}(\xi)a^2 + rr_0 \cos\{\theta + \text{sig}(\xi)\text{sig}(\eta)\theta_0\}$$

$$\Delta_U(\xi, \eta) = x\eta + y\xi + rr_0 \sin\{\theta + \text{sig}(\xi)\text{sig}(\eta)\theta_0\},$$

$$\text{sig}(x) \equiv \begin{cases} 1, & x \geq 0 \\ -1, & x < 0 \end{cases}$$

$$\theta_\Delta = \tan^{-1} \left(\frac{\Delta_U(\xi, \eta)}{\Delta_L(\xi, \eta)} \right)$$

$$P_k = \left(\frac{\alpha_4}{A_{14}} + (-1)^k \frac{\alpha_2}{A_{32}} \right) \cos \theta_p + \left(\frac{\alpha_3}{A_{32}} + (-1)^k \frac{\alpha_1}{A_{14}} \right) \sin \theta_p$$

$$Q_k = \left(\frac{\alpha_4}{A_{34}} + (-1)^k \frac{\alpha_2}{A_{12}} \right) \cos \theta_m + \left(\frac{\alpha_1}{A_{12}} + (-1)^k \frac{\alpha_3}{A_{34}} \right) \sin \theta_m,$$

($k = 1, 2$)

$$T_1 = \left(\frac{\alpha_1}{A_{12}} + \frac{\alpha_3}{A_{34}} \right) (x_0 \cos \theta_p + y_0 \sin \theta_p) +$$

$$\left(\frac{\alpha_2}{A_{12}} + \frac{\alpha_4}{A_{34}} \right) (y_0 \cos \theta_p - x_0 \sin \theta_p)$$

$$U_1 = \left(\frac{\alpha_2}{A_{32}} + \frac{\alpha_4}{A_{14}} \right) (y_0 \cos \theta_m + x_0 \sin \theta_m) -$$

$$\left(\frac{\alpha_1}{A_{14}} + \frac{\alpha_3}{A_{32}} \right) (x_0 \cos \theta_m - y_0 \sin \theta_m)$$

$$V_1 = \left(\frac{A'_{32}}{A_{32}^2} - \frac{A'_{14}}{A_{14}^2} \right) \cos \theta_p + 2 \left(\frac{\alpha_1 \alpha_4}{A_{14}^2} - \frac{\alpha_3 \alpha_2}{A_{32}^2} \right) \sin \theta_p$$

$$W_1 = \left(\frac{A'_{12}}{A_{12}^2} - \frac{A'_{34}}{A_{34}^2} \right) \cos \theta_m + 2 \left(\frac{\alpha_3 \alpha_4}{A_{34}^2} - \frac{\alpha_1 \alpha_2}{A_{12}^2} \right) \sin \theta_m$$

$$\theta = \frac{1}{2} \left(\tan^{-1} \frac{y}{x-a} + \tan^{-1} \frac{y}{x+a} \right),$$

$$\theta_0 = \frac{1}{2} \left(\tan^{-1} \frac{y_0}{x_0-a} + \tan^{-1} \frac{y_0}{x_0+a} \right)$$

$$\theta_p = \theta + \theta_0, \quad \theta_m = \theta - \theta_0$$

$$\kappa = \begin{cases} (3 - \nu)/(1 + \nu) & \text{(plane stress)} \\ (3 - 4\nu) & \text{(plane strain)} \end{cases}$$

where ν is Poisson's ratio.

The y -directional displacement of the infinite plate with a crack under remote uniform normal stress σ_0 is given by[5]

$$v = \frac{\sigma_0}{4\mu} \mathbf{F}(x, y, a)$$

$$\mathbf{F}(x, y, a) = \mathbf{L}(x, y) + \mathbf{M}(x, y, a) \tag{4}$$

Where

$$\mathbf{L}(xy) = (\kappa + 1)y/2$$

$$\mathbf{M}(x, y, a) = \left\{ \kappa r - (x^2 + y^2 - a^2)/r \right\} \sin \theta - (\kappa - 1)y \tag{5}$$

From Fig. 2, the displacements at the welding lines of the cracked plate and the reinforced plate are presented in the following form,

$$v_c(x) = \frac{\sigma_0}{4\mu_c} \mathbf{F}_c(x, y_0, a) - \frac{1}{4\pi\mu_c t_c} \int_0^\infty f(x_0) \mathbf{H}_c(x, x_0, y_0, a) dx_0$$

$$v_r(x) = \frac{1}{4\pi\mu_r t_r} \int_0^\infty f(x_0) \mathbf{I}_r(x, x_0, y_0) dx_0 \tag{6}$$

Substituting from eq. (6) into eq. (1), we obtain

$$\mathbf{F}_c(x, y_0, a) - \frac{1}{\pi} \int_0^\infty \frac{f(x_0)}{\sigma_0 t_c} \left[\mathbf{H}_c(x, x_0, y_0, a) + \frac{1}{\gamma} \mathbf{I}_r(x, x_0, y_0) \right] dx_0 = 0 \quad (7)$$

where $\gamma = \mu_r t_r / \mu_c t_c$ is the stiffness ratio.

In order to solve the problem, the distributed load equation is divided into two terms, the term by the crack effect and the term without the crack effect, as follows,

$$\frac{f(x_0)}{\sigma_0 t_c} = \bar{q}(x_0) + \bar{s}_0 \quad (8)$$

where \bar{s}_0 is related to the uniform distributed load, which occurs in the case of reinforcing an infinite plate without a crack. \bar{s}_0 is presented in the following form,

$$s_0 = \frac{\kappa_c + 1}{8 \left[\frac{1}{\gamma} \left(\frac{\kappa_c - 1}{\kappa_c + 1} \right) + \frac{\kappa_c - 1}{\kappa_c + 1} \right]} \quad (9)$$

Substituting from eq. (8) into eq. (7), and introducing the normalized factor, $\bar{x} = x/a$, $\bar{x}_0 = x_0/a$, $\bar{y}_0 = y_0/a$, we obtain the following singular integral equation,

$$(1 - \bar{s}_0) \mathbf{M}_c(\bar{x}, \bar{y}_0, 1) = \frac{1}{\pi} \int_0^\infty \bar{q}(\bar{x}_0) \left[\mathbf{H}_c(\bar{x}, \bar{x}_0, \bar{y}_0, 1) + \frac{1}{\gamma} \mathbf{I}_r(\bar{x}, \bar{x}_0, \bar{y}_0) \right] d\bar{x}_0 \quad (10)$$

Solving the singular integral equation for $\bar{q}(\bar{x}_0)$ and substituting from the result into the following equation[5], we can obtain the stress intensity factor by reinforcement force due to the crack effect.

$$\lambda = \sigma_0 \sqrt{\pi a} \int_0^\infty \bar{q}(\bar{x}_0) h_c(\bar{x}_0, \bar{y}_0) d\bar{x}_0 \quad (11)$$

$$h(\bar{x}_0, \bar{y}_0) = \frac{2}{\pi} \left\{ \frac{\sin \theta_0}{\bar{r}_0} - \frac{2\bar{y}_0}{(\kappa + 1)\bar{r}_0^3} (\bar{x}_0 \cos 3\theta_0 + \bar{y}_0 \sin 3\theta_0) \right\} \quad (12)$$

Where $\bar{r}_0 = r_0/a$

In conclusion, the stress intensity factor of the crack is obtained by eqs. (9) and (11) as follows,

$$\frac{K_I}{\sigma_0 \sqrt{\pi a}} = 1 - \bar{s}_0 - \bar{\lambda} \quad (13)$$

where $\bar{\lambda} = \lambda / \sigma_0 \sqrt{\pi a}$ is the normalized stress intensity factor.

2.2. The method of solving the singular integral equation

Substituting from $\bar{x} = (1 + \tau)/(1 - \tau)$ and $\bar{x}_0 = (1 + \xi)/(1 - \xi)$ into eq. (10) we obtain the following equation.

$$(1 - \bar{s}_0) \mathbf{M}_c(\tau, \bar{y}_0, 1) = \frac{2}{\pi} \int_{-1}^1 \frac{\bar{q}(\xi)}{(1 - \xi)^2} \left[\mathbf{H}_c(\tau, \xi, \bar{y}_0, 1) + \frac{1}{\gamma} \mathbf{I}_r(\tau, \xi, \bar{y}_0) \right] d\xi \quad (14)$$

Since $\bar{q}(\xi)$ is nonsingular in the case of $\xi = \pm 1$, we introduce the nonsingular function, $\phi(\xi)$ as follows,

$$\bar{q}(\xi) = \phi(\xi) \sqrt{1 - \xi^2} \quad (15)$$

Substituting from eq. (15) into eq. (14) and introducing Erdogan and Gupta's method[6], eq.(14) is reduced to the following equation,

$$(1 - \bar{s}_0) \mathbf{M}_c(\tau_k, \bar{y}_0, 1) = \frac{2}{N + 1} \sum_{n=1}^N \left\{ \left(\frac{1 + \xi_n}{1 - \xi_n} \right) \phi(\xi_n) \beta(\tau_k, \xi_n, \bar{y}_0) \right\}, \quad k = 1, 2, \dots, (N + 1) \quad (16)$$

Where

$$\xi_n = \cos \left(\frac{n\pi}{N + 1} \right), \quad \tau_k = \cos \left[\frac{(2k - 1)\pi}{2(N + 1)} \right],$$

$$\beta(\tau_k, \xi_n, \bar{y}_0) = \mathbf{H}_c(\tau_k, \xi_n, \bar{y}_0, 1) + \frac{1}{\gamma} \mathbf{I}_r(\tau_k, \xi_n, \bar{y}_0)$$

The unknown function, $\phi(\xi)$ in eq. (16) has been obtained with $N=90$. Substituting from the results into eq. (15) and eq. (11), the stress intensity factor is calculated by eq. (13). In the case of $N=100$, the change of the stress intensity factor is less than 0.1%.

3. Results and discussion

The finite element method with ANSYS 5.3 is used to verify the theory and an eight node rectangular element is used for the numerical analysis where $\nu = 0.3$ is used.

Table 1 provides a comparison of dimensionless stress intensity factors between the present solution and the FEM analysis. As seen in the table, the values from the FEM analysis are about 1~10% greater than those from the present theory, and this appears to be attributable to the reinforcement force in the x -direction.

TABLE 1
Comparison of the dimensionless stress intensity factors between the present solution and the FEM analysis

y_0/a	$\gamma = 0.1$		$\gamma = 0.5$		$\gamma = 1.0$		$\gamma = 2.0$	
	present	FEM	present	FEM	present	FEM	present	FEM
0.5	0.753	0.787	0.384	0.411	0.234	0.254	0.123	0.137
1.0	0.833	0.845	0.491	0.512	0.316	0.335	0.171	0.188
2.0	0.876	0.885	0.576	0.592	0.392	0.412	0.223	0.243
5.0	0.896	0.903	0.622	0.637	0.439	0.453	0.258	0.280
10.0	0.899	0.907	0.631	0.642	0.447	0.462	0.265	0.285

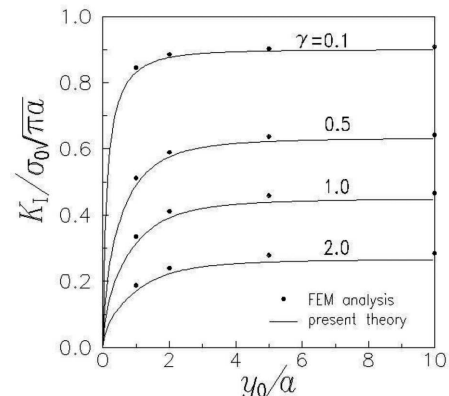

Fig. 3. Dimensionless stress intensity factors as a function of the seam welding location and the stiffness ratio

Fig. 3 shows the stress intensity factors as a function of the seam welding location and the stiffness ratio. The solid lines in the figure indicate the values yielded by the present theory and the spots • indicate those by the FEM analysis. From Fig. 3, we see that the stress intensity factor decreases as the stiffness ratio becomes larger and that the stress intensity factor approaches zero as y_0 becomes closer to zero. This indicates that reinforcement effect improves as the welding line is situated closer to the crack.

Fig. 4 shows the stress intensity factor as function of the stiffness ratio. From Fig. 4, we see that the stress intensity factor decreases as the welding line is situated closer to the crack and as the stiffness ratio of the cracked plate and the reinforcement sheet increases, which indicates that the reinforcement effect is improved. We also see that the normalized stress intensity factor approaches 1 as the stiffness ratio declines to zero.

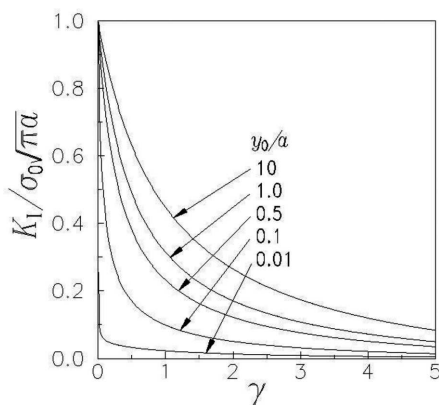

Fig. 4. Dimensionless stress intensity factors as a function of the stiffness ratio

4. Conclusions

Through a theoretical analysis to determine the stress intensity factor for a cracked plate reinforced with a sheet by symmetric seam welding, the following conclusions are obtained.

1. The stress intensity factor for a cracked plate reinforced with a sheet by seam welding is determined with the singular integral equation method.
2. The theory is verified by comparing the results of the present study with those of a numerical analysis and the results from the present analysis are deemed reasonable.
3. The reinforcement effect improves as the welding line is situated closer to the crack and the stiffness ratio of the cracked plate and the reinforcement plate increases.

REFERENCES

- [1] R. Greif, J.L. Sanders, Jr. The effect of a stringer on the stress in a cracked sheet. *Trans. ASME, J. Appl. Mech.* **32**(1), 59-66 (1965).
- [2] A.F. Liu, J.C. Ekvall, Material toughness and residual strength of damage tolerant aircraft structures. *Damage tolerance in aircraft structures*, ASTM STP **486**, 98-121 (1971).
- [3] H.P. Kan, M.M. Ratwani, Nonlinear adhesive behavior effects in cracked metal to composite bonded structures. *Engng. Fract. Mech.* **15**, 123-130 (1981).
- [4] MIL-HDBK-5C, Metallurgical joints, USAF (1976).
- [5] Ok Hwan Kim, Stress intensity factor for a cracked sheet reinforced with a plate by spot welding. Ph. D Thesis, Yonsei University, Seoul Korea, 1995, February.
- [6] F. Erdogan, G.D. Gupta, On the numerical solution of singular integral equations. *Q. Appl. Math.* **29**, 525-534 (1972).